

Duct Smoke Detector

HOCHIKI AMERICA

The AL-HADH-UP(X) duct mounted photoelectric smoke detectors assure detection of smoke in the air moving through an air conditioning or ventilating duct, 2-wire (powered by the panel), 4-wire (powered by a UL Listed 24VDC power supply)*, as well as 120VAC single station models are available from the factory. It is also possible to convert any 2-wire model to a 4-wire model by changing the jumper position on the terminal block in the field.

All models have 1 form C and 1 form A set of contacts available which transfer on alarm. Contact rating form C 2A-30VDC, form A 1A-120VAC.

The plug-in photoelectric type detector head is expressly suited for the cooler smoke most generally found in air handling ducts. Duct smoke detectors are not suitable for area or room-type fire protection.

Sampling tubes can be cut at installation and should extend across the full width of the duct on which the unit is mounted. Tube orientation is keyed to assure the proper air sample is taken from the duct.

A status LED on the head is visible through the transparent front cover. This LED blinks to indicate power is received at the head and on alarm lights steadily. To reset to normal the panel must be reset on 2-wire units, the power interrupted on 4-wire units and the reset switch operated on the AC version.

*An end-of-line relay must be attached to terminals 2 and 3 of the last unit in all 4-wire installations.

Specifications

Outputs: All units have 1 form C and 1 form A dry contacts; form C rated at 2A-30VDC, form A rated at 1A-120VAC. On the 4-wire unit the form A contact is dedicated for alarm signaling service only. All contacts transfer on alarm.

All units have a single 24VDC positive output during alarm for remote signaling.

Operating Temperature: Listed at 32F-100F.

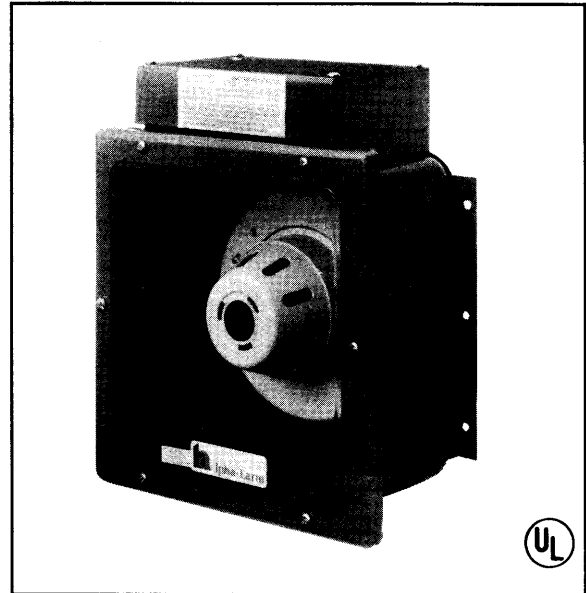

MODEL AL-HADH-UP(X)
(X) = 1, 2, 4, or 120. (1) 220 ohm, (2) 750 ohm, (4) 4-wire, (120) 120VAC.

Supervision: With EOL Resistor systems, removal of the head causes the panel to go into trouble by breaking the detection loop circuit. The same is true of the 4-wire and AC unit except the EOL relay contacts open to break the detection loop circuit.

Operating Voltage: All 2- and 4-wire units operate on full wave rectified voltage, 16 to 30VDC. The AC unit operates on 120VAC line voltage.

Note: Refer to NFPA 90A for guidelines to consider during placement and installation of this duct housing. Improper placement is just as bad as faulty installation. *For your own copy of 90A write to NATIONAL FIRE PROTECTION ASSOCIATION, Batterymarch Park, Quincy, MA 02269.*



HOCHIKI AMERICA

5415 Industrial Drive • Huntington Beach, CA 92649
(714) 898-0795 • FAX (714) 892-2809

Installation

Installation and Test instructions are publication (HADH-11586). A copy of this publication is packed with each unit. Testing is done with a special test meter (DHTK-1). An exhaust tube is included with each unit but sampling tubes (see FIG. 1) must be ordered for each installation. For ducts with air velocities of 400-4000 FPM.

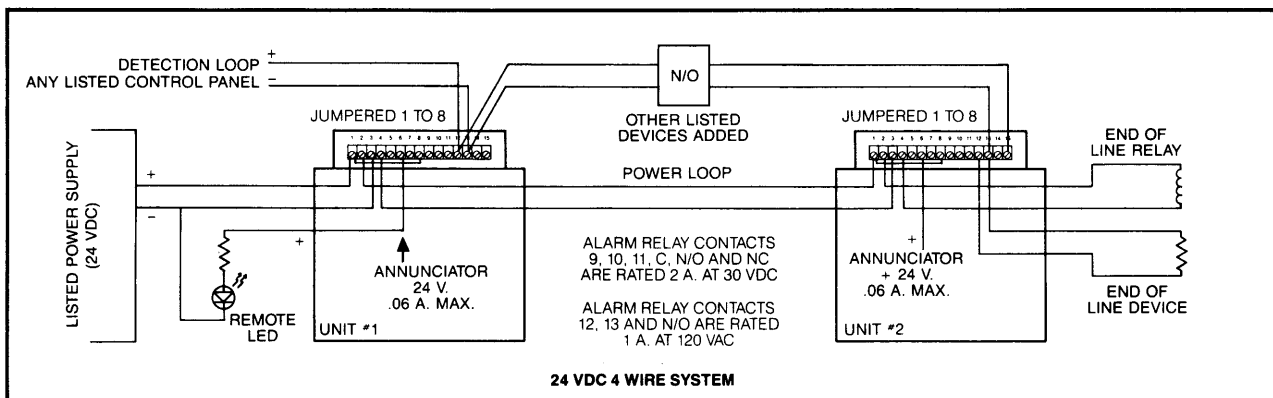
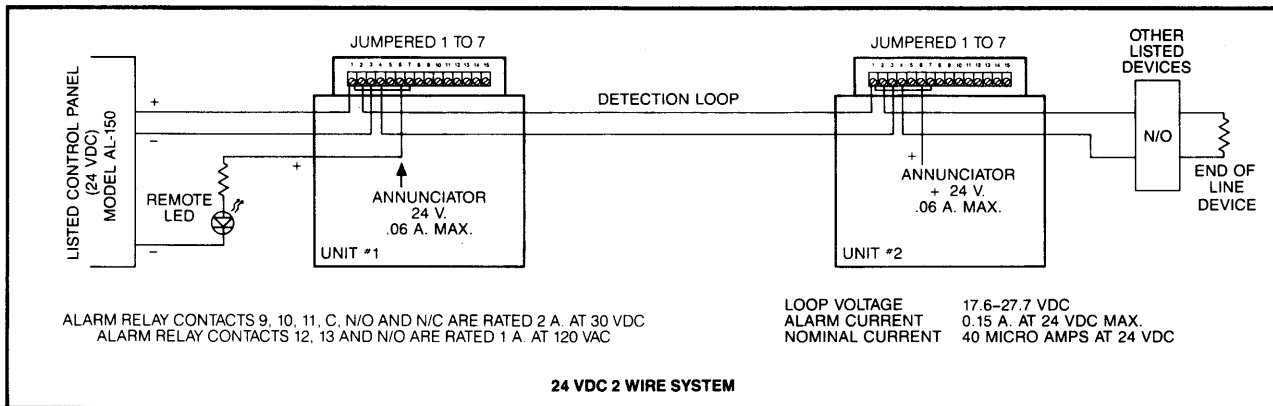
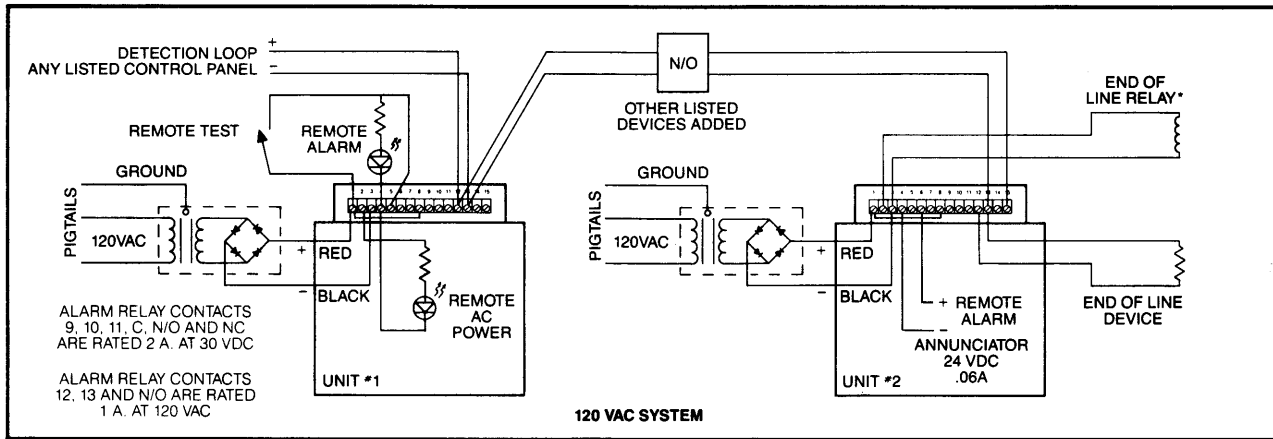
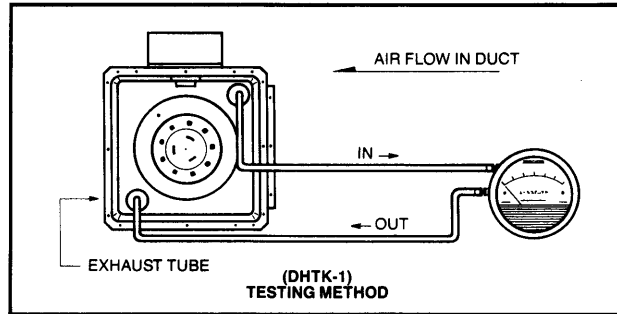
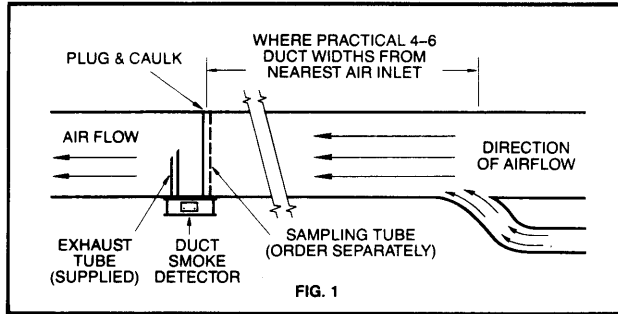

ELECTRICAL SPECIFICATION

The AL-HADH-UP Duct Housing can be ordered in any of the three electrical configurations listed below.

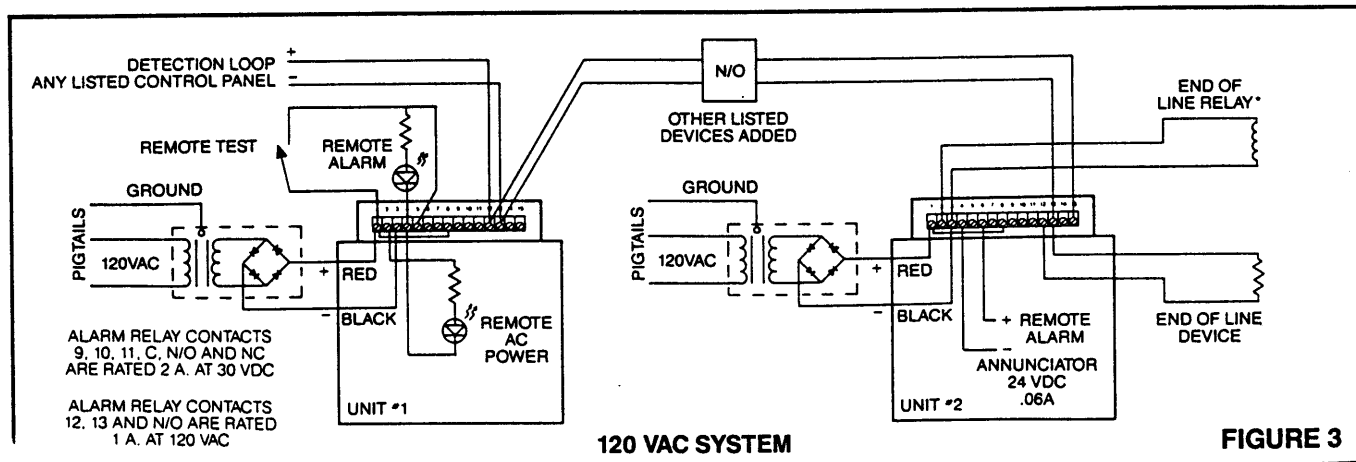
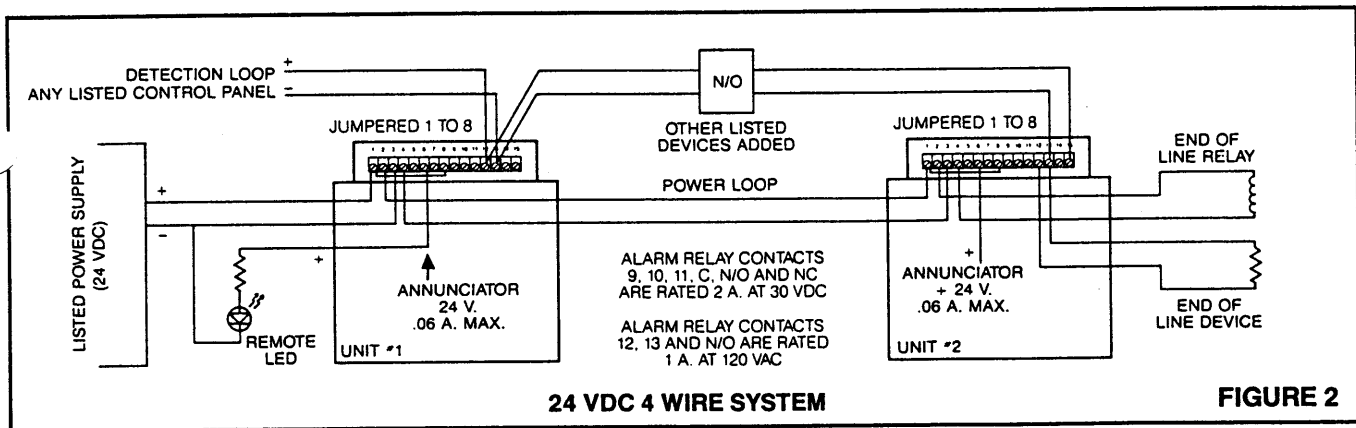
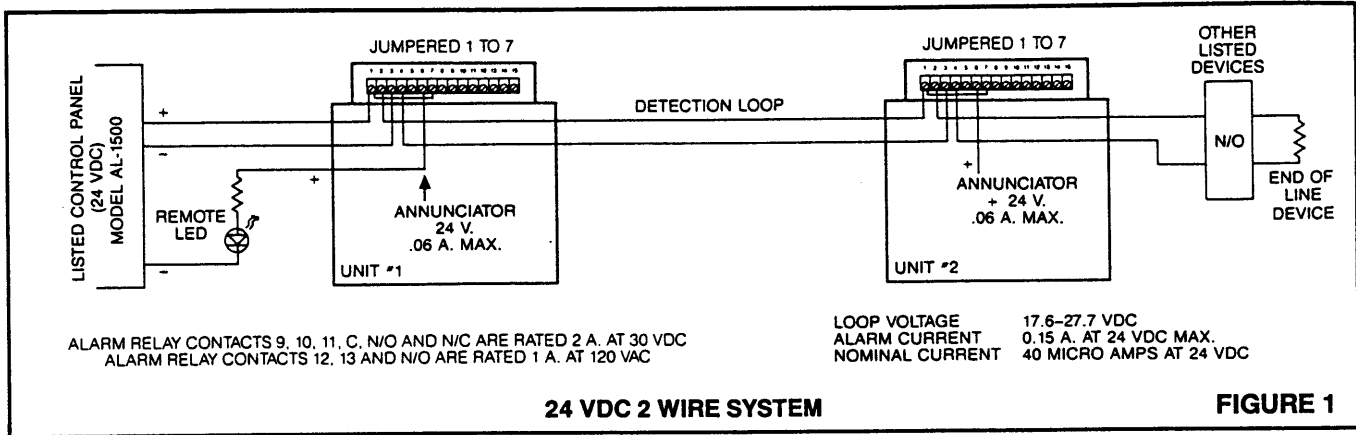

* DENOTES THAT AN END-OF-LINE RELAY MODULE IS NEEDED. USE HA-ELR MODULE (26 mA CURRENT DRAW). WIRE TO TERMINALS AS FOLLOWS: RED WIRE-TERMINALS 1 OR 2, BLACK WIRE-TERMINALS 3 OR 4, & REMAINING TWO WIRES-ON 14 & 15.

PRE-INSTALLATION:

The AL-HADH-UP___ Duct Housing should be installed in a location of relatively non-turbulent air flow and within the intended operating velocity range of 400 to 4000 feet per minute. Whenever possible, locate detectors a minimum of six duct widths downstream from bends or inlets. Such locations ensure that air flow will be non-turbulent and the smoke will be properly mixed with air in the duct for maximum detector efficiency. (See Figure 4). Do not locate Duct Detectors near exhaust or return air dampers as air flow could be restricted. Locate Air Duct Detectors on the return duct of the equipment's air handling system. However, Detectors should NOT be installed in the return air damper branch. Locate detectors on the downstream side of filters to sense fires in the filters. However, should the filters become dirty, sufficient air flow may not be available for proper detector operation. Whenever possible, locate detectors where they can be conveniently observed and readily serviced. Locate Detectors in return air ducts ahead of mixing areas. Do not locate next to outside air inlets unless you want to monitor smoke entry to the handling system from an adjacent area. Locate detectors upstream of air humidifiers and cooling coils.

APPLICATION NOTE:

The NFPA states that duct smoke detectors must not be used as substitutes for open area protection. The AL-HADH-UP___ is intended for use in the control of Air Handling Equipment for the purposes of closing dampers or shutting down air handling units.

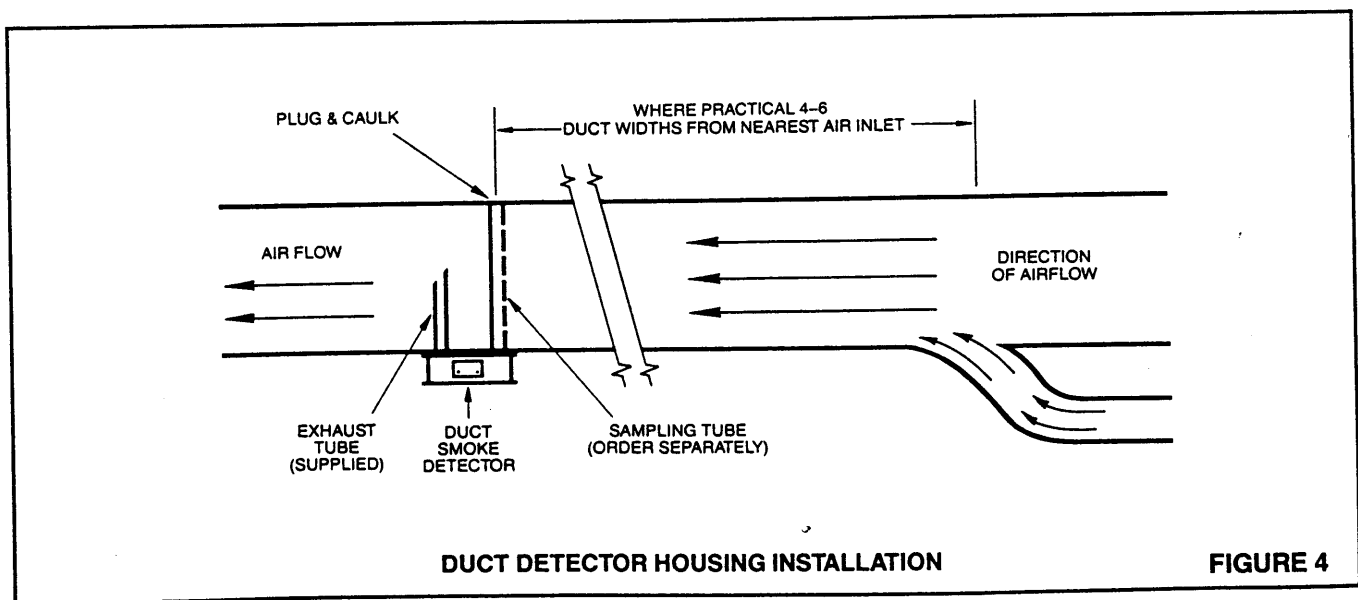

INSTALLATION PROCEDURES:

- (1). Tape template (Figure 8) on the duct surface as shown in (Figure 5).
- (2). Drill six (6) $\frac{1}{8}$ " holes (marked "A" Figure 8) and two (2) $1\frac{1}{2}$ " holes (marked "B" Figure 8) as located on template.
- (3). If duct is more than three (3) feet wide, punch a one (1) inch hole in the duct wall directly opposite the upstream $1\frac{1}{2}$ " hole. (See Figure 6).
- (4). Select proper inlet tube and cut to length as shown in Table A.

TABLE "A"

OVERALL DUCT WIDTH	SUGGESTED CUT LENGTH
12"	1" less than Duct Width
13" to 36"	1" less than Duct Width
36" to 46"	$\frac{1}{2}$ " longer than Duct Width
46" to 71"	$\frac{1}{2}$ " longer than Duct Width
71" to 95"	$\frac{1}{2}$ " longer than Duct Width

- (5). Install the inlet tubes in the upstream tubing receptor located on the rear of the Duct Housing by inserting the slotted end into the fitting provided. Be sure that one of the slots on the end of the tube engages the pin inside the special conduit fitting, so that the holes face directly into the air stream when the detector housing is installed on the duct. The tube is therefore locked against accidental turning away from the air stream. Securely tighten the compression fitting to lock the inlet tube in place. (See Figure 6).
- (6). Install the exhaust tube into the down stream tube receptor. Place exhaust tube such that the open flare or angle cut faces directly down stream of air flow. Be sure that one of the slots on the end of the tube engages the pin in the fitting. Securely tighten the compression fitting to lock the exhaust tube in place. (See Figure 6).
- (7). Insert the inlet tube and exhaust tube into the holes previously cut in the duct. Insert the inlet tube through the hole on the far side of the duct if a support hole is being used.
- (8). Secure the housing to the duct using the six (6) number 8 sheet metal screws provided in the accessory kit.
- (9). If the inlet tube protrudes through the far side of the duct, seal the opening around the tube on the outside of the duct with duct sealant.
- (10). If conduit is required, route conduit to the most convenient knockout and secure to assembly using suitable fittings.
- (11). Connect wires to the appropriate terminals within the Duct Housing in accordance with the system wiring diagram, the appropriate typical installation diagram and Figures 1, 2, 3.

HOCHIKI AMERICA CORPORATION

INSTALLATION INSTRUCTIONS AL-HADH-UP

DWG. HA-J7087
ISSUED 3/87

GENERAL DESCRIPTION:

The AL-HADH-UP Air Duct Detector Housing is designed to sample air and detect smoke in air handling ducts. Auxiliary contacts exist for Alarm, Supervisory, and Control Functions.

The housing uses the Hochiki SLG-24FDH Photoelectric Smoke Detector.

Air is sampled via sampling tubes which extend into the ducts. The housing may be used with air handling ducts from 8" to 95" wide.

The transparent smoke chamber cover makes it possible to see the status of the detectors alarm/power supervisory LED. It also allows easy inspection for cleanliness of the inside area without the need for disassembly.

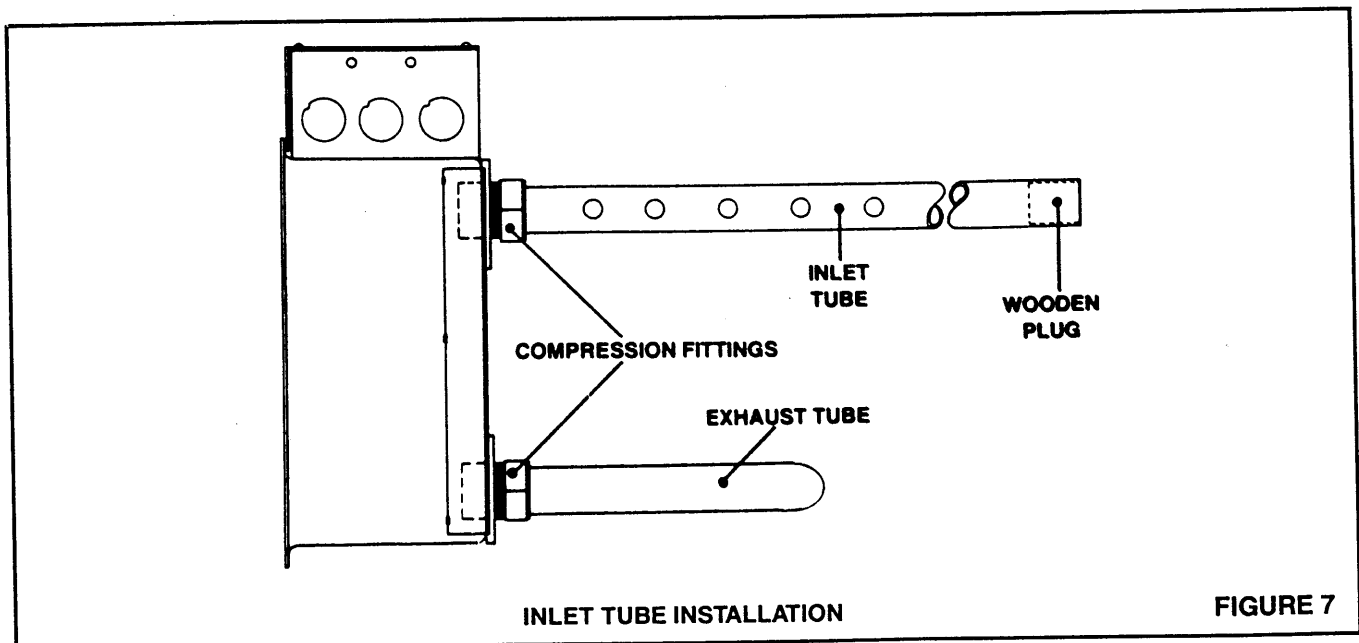
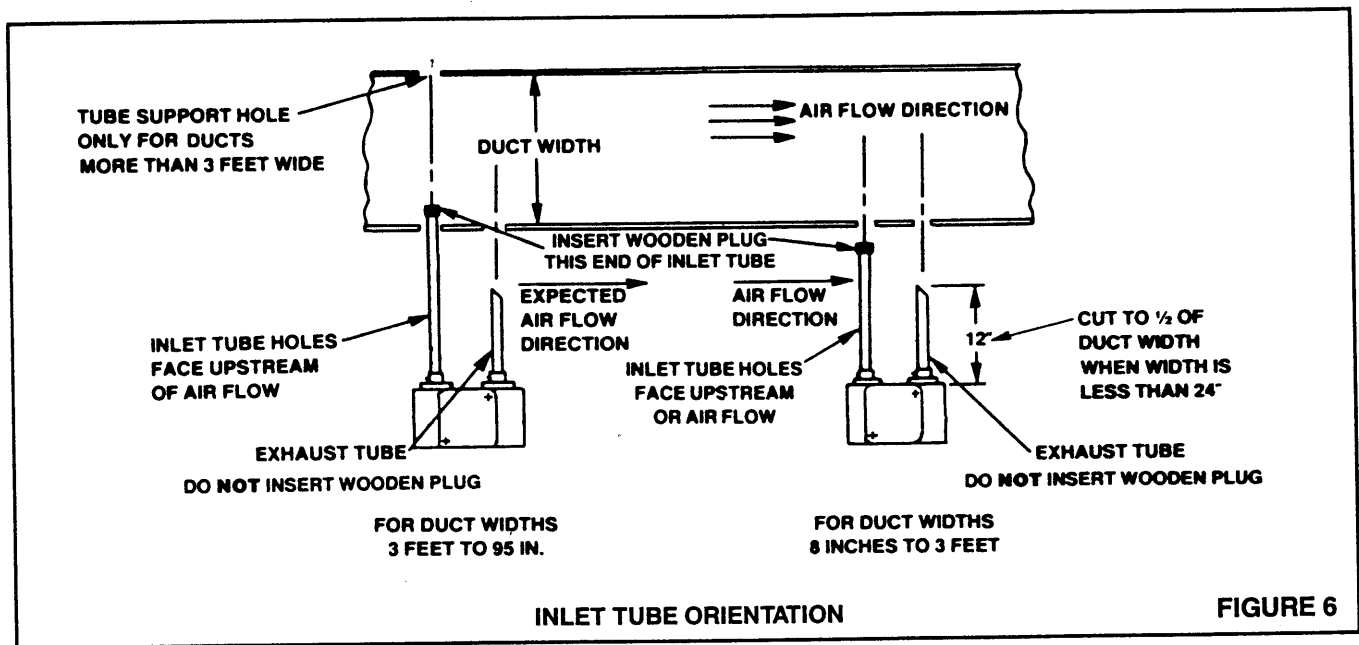
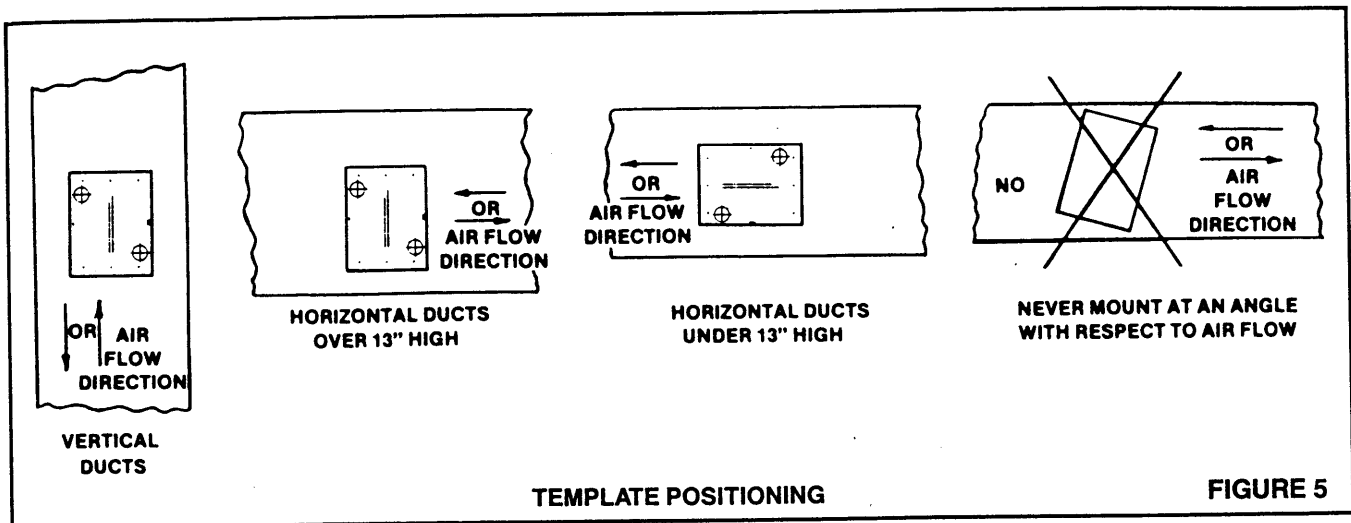

NOTE: See Installation Wiring Diagrams Fig. 1, 2, 3 for all Detector terminal connections. The Terminal Strip is provided with clamping plates. Wire connections are made by stripping $\frac{1}{2}$ " insulation from the end of the wire, sliding the bare end under the plate, and tightening the screw. Two (2) wires may be clamped, one on each side of the screw, but the wire should not be twisted or looped. It must be broken so that electrical supervision is maintained. (See Figure 9).

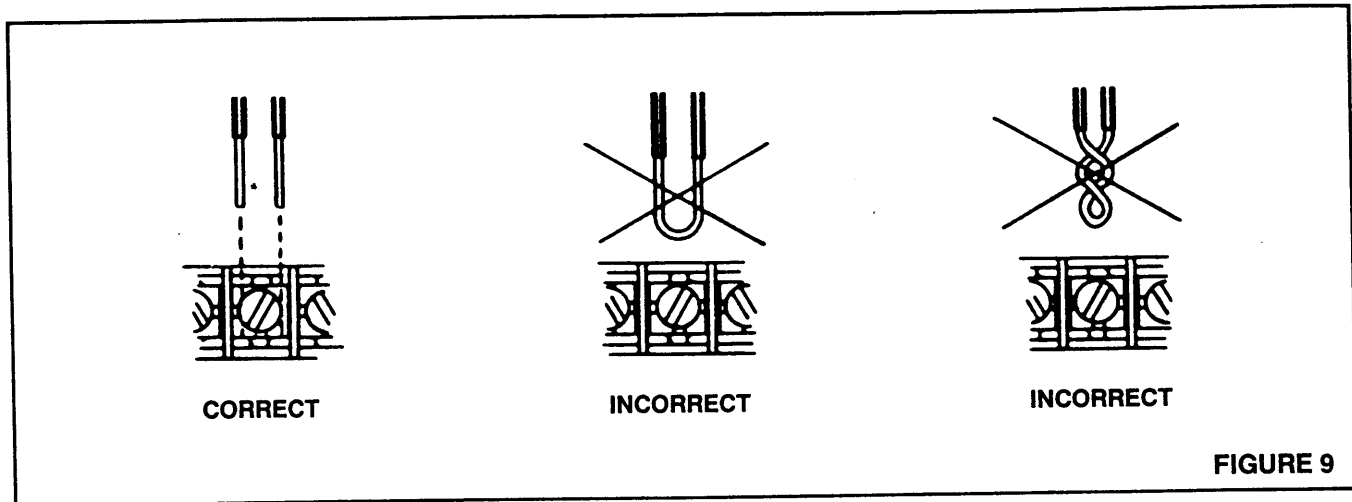

- (12). Perform all wiring in accordance with the requirements of the National Electrical Code, Local Codes, and Applicable Specific System Drawings.
- (13). With Air Handling unit OFF and power applied to the detector, introduce smoke into the detector or activate the built-in test feature as described in the Detector Head Operating Instructions. Observe alarm LED operation. Restore normal operation to detector by momentarily removing power or by removing and replacing the detector head after smoke has been cleared from its chamber.
- (14). With the Air Handling unit turned ON and all filters and dampers in place, measure the air differential pressure using the DHTK-1 test kit. Take measurements from inside of the Detector Housing before the clear plastic cover is installed. Measure the difference in pressure between the intake tube receptor and the exhaust tube receptor. The pressure differential for all duct velocities between 400 and 4000 feet per minute shall not be less than 0.03 inches of water but not greater than 1.85 inches of water.
- (15). After testing is completed, install the clear plastic cover. Secure in place using the six (6) screws provided. Tighten securely to seat the cover firmly against the gasket and provide an air-tight seal.

MAINTENANCE:

The Sampling Tube holes should be checked periodically for cleanliness, thus assuring easy air entry. The Maintenance Program of the particular detector used should be carried out in accordance with provided bulletin. Vacuuming the Detector's air entry areas should be performed on a six-month basis, or as required by local authorities. The transparent chamber cover may be cleaned with a mild soap and warm water solution when required.

TOP

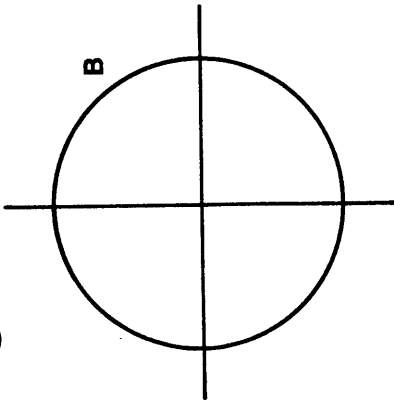

HOLES MARKED "A" ARE FOR SHEET METAL SCREWS. HOLES ARE 1/8" DIA.

HOLES MARKED "B" ARE FOR SAMPLING AND EXHAUST TUBES. HOLES ARE 1 1/2" DIA.

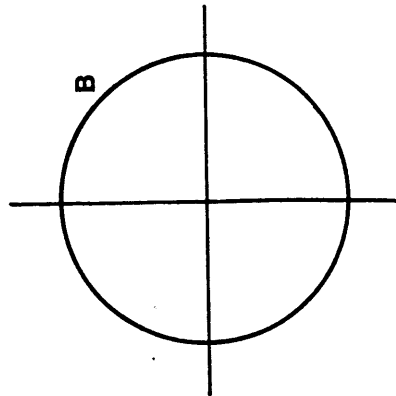

DHTK-1 INSTRUCTION SHEET

With the detector mounted on the duct and air flowing through the duct you should check the pressure differential between the sampling and exhaust tubes in the following manner. The proper pressure differential is 0.03 to 1.85 in of water.

- A. Remove the face plate (optionally, you may also remove the detector head).
- B. Insert the meter feed tubes A and B into the air extender tubes in the duct with A going to the exhaust side and B to the sampling side.

- C. Read directly from the meter indication the pressure differential. If this differential is not within the prescribed limits, the application is unsuitable for the detector and may not function as intended. You may increase or decrease the air flow within the air duct but there is no other variable with which to work. Increasing the air flow should increase the pressure differential while decreasing air flow will decrease the pressure differential.

