

FireNET

FN-LCD-S Serial Annunciator

Installation and Operation Manual

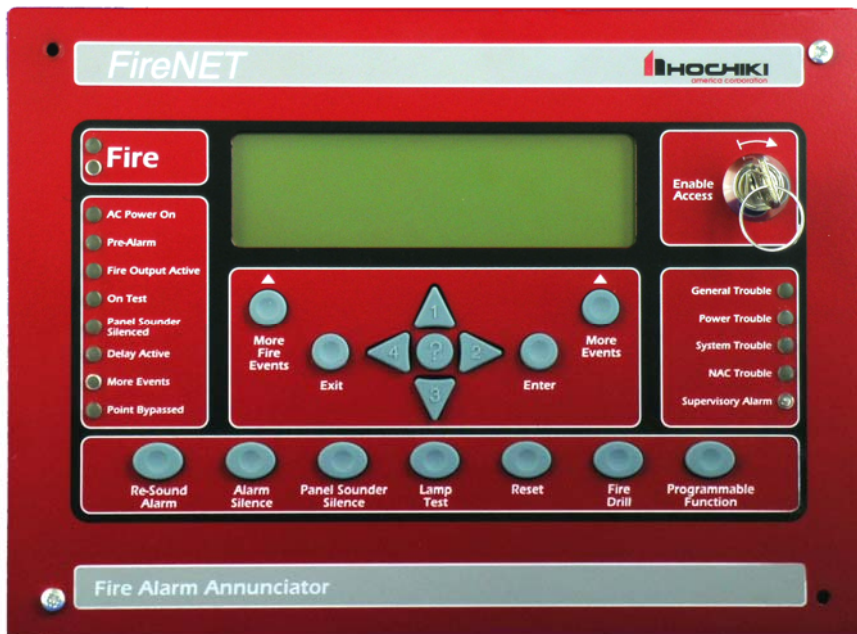

Hochiki America Corporation
7051 Village Drive, Suite 100
Buena Park, CA 90621-2268
714.522.2246 Corporate Headquarters
800.845.6692 Technical Support
<http://www.hochiki.com>

Version 1.0
Created: 02/20/09
Updated: 03/13/09

PN# 1700-10970

Table of Contents

| | |
|---|-----------|
| Table of Contents | 2 |
| Section 1 – Introduction | |
| | 3 |
| 1.1 Limitations of Fire Alarm Systems | 3 |
| Section 2 – General Wiring Specifications | |
| | 6 |
| Section 3 – Installing the FN-LCD-S Serial Annunciator | |
| | 7 |
| 3.1 Environmental Specifications..... | 7 |
| 3.2 Addressing..... | 8 |
| 3.3 Installation of the FN-LCD-S..... | 9 |
| 3.4 Power Connections..... | 10 |
| 3.4.1 Using the Power Output of the FN-LCD-S | 10 |
| 3.5 COMMS Connection..... | 11 |
| 3.6 Terminating..... | 11 |
| 3.7 Programming the FireNET Panel for the Annunciator..... | 13 |
| Section 4 – Operation of the FN-LCD-S Serial Annunciator | |
| | 14 |
| 4.1 Fire Condition | 14 |
| 4.2 Trouble Condition | 15 |
| 4.3 Supervisory Condition..... | 16 |
| 4.4 Pre-Alarm Condition | 17 |
| WARRANTY | 18 |

Section 1 – Introduction

The FN-LCD-S serial annunciator is listed as compatible for use with the FireNET and FireNET Plus analog fire alarm control panels.

1.1 Limitations of Fire Alarm Systems

Follow Recommended Installation Guidelines: To achieve early fire detection, fire detection sensors should be installed in all rooms and areas of a house, apartment, or building in accordance with the recommendations of the National Fire Protection Association Standard 72 (NFPA 72), manufacturer's recommendations, state and local codes, and the recommendations contained in Guide for the Proper Use of System Smoke Detectors, which is made available at no charge to all installing dealers. Generally, the standards and recommendations include the following (but installers should refer to the specific guidelines above before installing):

- Sleeping Rooms: Smoke detectors should be installed in every sleeping room.
- Hallways: More than one smoke detector should be installed in a hallway if it is more than 30 feet long.
- At least Two Smoke Detectors: There should never be less than two smoke detectors per apartment or residence.
- Smoke Detectors in Alarm, Electrical, or Phone Locations: Smoke detectors should be located in any room where an alarm control is located or an alarm control connects to an electrical source or phone line. If detectors are not so located, a fire within the room could prevent the alarm control from reporting a fire.
- Notification Systems: All fire alarm systems require notification devices, including sirens, bells, horns, and/or strobes. In residential applications, each automatic alarm initiating device when activated should cause the operation of alarm notification device that should be clearly audible in all bedrooms over ambient or background noise levels (at least 15dB above noise) with all intervening doors closed.
- Alarm in Every Bedroom and Level of Residence: A smoke detector with an integral sounder (smoke alarm) should be located in every bedroom and an additional notification device should be located on each level of a residence.
- Maintenance: A maintenance agreement should be arranged through the local manufacturer's representative and maintenance should be performed annually by authorized personnel only. To keep a fire alarm system in excellent working order, ongoing maintenance is required per the manufacturer's recommendations and UL and NFPA standards. At a minimum the requirements of Chapter 7 of NFPA 72 (1999) shall be followed.
- Test Weekly: The alarm system should be tested weekly to make sure all sensors and transmitters are working properly. The most common cause of an alarm system not functioning when a fire occurs is inadequate maintenance.

Alarms Cannot Guarantee Warning or Protection: Fire alarm system cannot guarantee warning or protection against fire in every potential situation. A study by the Federal Emergency Management Agency (an agency of the United States government) indicated that smoke detectors may not go off or give early warning in as many as 35% of all fires.

Limitation on Fire Alarm Effectiveness: A fire alarm system may not provide timely or adequate warning, or simply may not function, for a variety of reasons. For example:

- No Detection: Particles of combustion or smoke from a developing fire may not reach the sensing chambers of smoke detectors because:
 1. **Barriers** (such as closed or partially closed doors, walls, or chimneys) may inhibit particle or smoke flow.
 2. Smoke particles may become **cold, stratify, or not reach** the ceiling or upper walls where detectors are located.
 3. Smoke particles may be **blown away** from detectors by air outlets.
 4. Smoke particles may be **drawn into air returns** before reaching the detector.
- No Multi-Floor Detection: In general, smoke detectors on one level of a structure cannot be expected to sense fires developing on another level.
- Insufficient Smoke: The amount of smoke present may be insufficient to alarm smoke detectors. Smoke detectors are designed to alarm, at various levels of smoke density. If such density levels are not created by a developing fire at the location of the detector, the detector will not go into alarm.
- Smoldering vs. Flaming Fires: Smoke detectors, even when working properly, have sensing limitations. Detectors that have photoelectric sensing chambers tend to detect smoldering fires better than flaming fires, which have little visible smoke. Detectors that have ionizing-type sensing chambers tend to detect fast flaming fires better than smoldering fires. Because fires develop in different ways and are often unpredictable in their growth, neither type of detector is necessarily best and a given type of detector may not provide adequate warning of a fire.
- False Alarms and Pre-Fire Disconnection: Smoke detectors are subject to false alarms and nuisance alarms and may have been disconnected by users. For example, a smoke detector located in or near a kitchen may go into nuisance alarm during normal operation of kitchen appliances. In addition, dusty or steamy environments may cause a smoke detector to falsely alarm. If the location of a smoke detector causes an abundance of false alarms or nuisance alarms, do not disconnect the smoke detector, call a professional to analyze the situation and recommend a solution.
- Fast Fires and Explosions: Smoke detectors cannot be expected to provide adequate warning of fires caused by arson and children playing with matches (especially within bedrooms), smoking in bed, violent explosions (caused by escaping gas, improper storage of flammable materials, etc.).
- Heat Detectors: Heat detectors do not sense particles of combustion and are designed to alarm only when heat on their sensors increases at a predetermined rate or reaches a predetermined level. Heat detectors are designed to protect property, not life.

- Unheeded Warning: Warning devices (including horns, sirens, and bells) may not alert people or wake up sleepers who are located on the other side of closed or partially open doors. A warning device that activates on a different floor or level of a dwelling or structure is less likely to awaken or alert people. Even persons who are aware may not notice the warning if the alarm is muffled by noise from a stereo, radio, air conditioner or other appliance, or by passing traffic. Audible warning devices may not alert the hearing impaired (strobes or other devices should be provided to warn these people). Any warning device may fail to alert people with a disability, deep sleepers, people who have recently used alcohol or drugs, or people on medication or sleeping pills.
 - Strobes: Strobes can under certain circumstances, cause seizures in people with conditions such as epilepsy.
 - Drills: Studies have shown that certain people, even when they hear a fire alarm signal, do not respond or comprehend the meaning of the signal. It is the property owner's responsibility to conduct fire drills and other training exercises to make people aware of fire alarm signals and instruct on the proper reaction to alarm signals.
 - Hearing Loss: In rare instances, the sounding of a warning device can cause temporary or permanent hearing loss.
- Telephone Transmissions Problems: Telephone lines needed to transmit alarm signals from a premises to a central station may be out of service or temporarily out of service. For added protection against telephone line failure, backup radio transmission systems are recommended.
- System Failure With Age or Lack of Maintenance: System components, though designed to last many years, can fail at any time. As a precautionary measure, it is recommended that smoke detectors be checked, maintained, and replaced per manufacturer's recommendations.
- Electrical Power Problems: System components will not work without electrical power. If system batteries are not serviced or replaced regularly, they may not provide battery backup when AC power fails.
- High Air Velocity or Dusty or Dirty Environments: Environments with high air velocity or that are dusty or dirty require more frequent maintenance.

Importance of Maintenance: In general, fire alarm systems and devices will not work without power and will not function properly unless they are maintained and tested regularly.

Alarm is Not Substitute for Insurance: While installing a fire alarm system may make the owner eligible for a lower insurance rate, an alarm system is not a substitute for insurance. Property owners should continue to act prudently in protecting the premises and the people in their premises and should properly insure life and property and buy sufficient amounts of liability insurance to meet their needs.

Section 2 – General Wiring Specifications

Care should be taken when wiring the system to avoid situations that would contribute to inducing electrical noise from one wire to another. Induced noise can interfere with telephone communications or cause erratic system operation. Follow these general guidelines to plan your system wiring prior to installation.

- Route high and low voltage wiring separately. Maintain a minimum 2” separation between high and low voltage wiring throughout the building.
- Route control panel wiring around the perimeter of the control panel enclosure. A minimum .25” separation is required between high and low voltage wiring.
- Identify which group each wire or cable is associated with from the list below. Isolate each group’s wiring as much as possible. Avoid running a single multi-conductor cable for multiple groups of conductors.
 - AC Power - Main Power Supply
 - Notification Appliances
 - SLC Circuits
 - Relay Outputs
 - Voltage Outputs
 - Remote Control and Auxiliary Inputs
 - Network Wiring (Shielded wire required)
 - RS485 Bus Wiring (Shielded wire required)
- Keep wiring from different groups separated as much as possible. If you must share the same conduit with different conductor groups consider using shielded cable.
- If shielded cable is used terminate the shield to the earth ground terminal block in the main control panel and leave open at field side of cable. Do not ground at both ends of cable.

Section 3 – Installing the FN-LCD-S Serial Annunciator

The FN-LCD-S Serial LCD Annunciator duplicates the indications of the FireNET or FireNET Plus fire alarm control panel. The FN-LCD-S connects to the control panel via the RS485 serial bus designated “COMMS” on the control board. Up to 15 FN-LCD-S annunciators may be connected via the COMMS bus to a single FireNET control panel.

Available colors are RED and CHARCOAL as identified below:

- FN-LCD-S-R = RED
- FN-LCD-S-C = CHARCOAL

All terminals on the FN-LCD-S serial annunciator can accept wire gauges from 22AWG to 14AWG.

3.1 Environmental Specifications

The FN-LCD-S annunciator should be installed in locations where it will NOT be exposed to temperatures outside the range of 32° F – 120°F or humidity outside the range of 10%-85% non-condensing.

The annunciator must be installed so that it is not subjected to damage by water and condensation. AVOID mounting the annunciator directly on exterior masonry walls, in areas subject to plumbing leaks, in areas subject to splash from sprinkler test valves, or in high humidity areas.

The FN-LCD-S serial annunciator is intended for installation in indoor environments in a dry location.

3.2 Addressing

Up to 15 FN-LCD-S serial annunciators may be connected to a control panel. Each annunciator must be set to a unique address before it is installed. The address for each annunciator is set using a 4-position DIP switch in binary fashion. Switches 1-4

represent the values 1, 2, 4, 8 respectively. To set the address, move only the switches whose values when added equal the address value you wish to set to the "ON" position. For example, moving switches 1 and 3 (whose values are 1 and 4 respectively) to the "ON" position sets the address of 5 into the annunciator. See the other examples below:

| Switch Number | Value |
|---------------|-------|
| 1 | 1 |
| 2 | 2 |
| 3 | 4 |
| 4 | 8 |

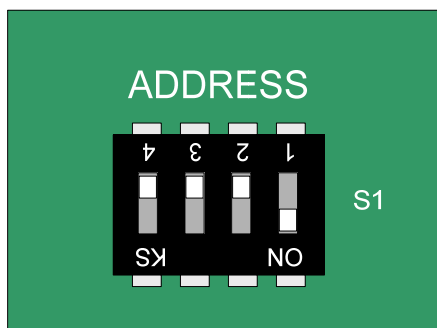

Address 1. Switch 1 is in the ON position.

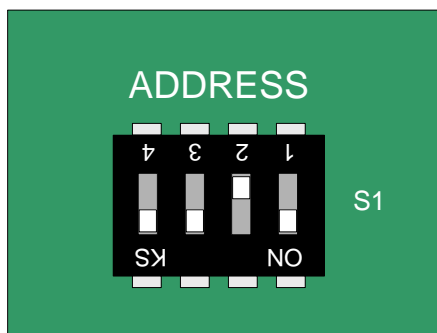

Address 13. Switches 1, 3 and 4 are in the ON position (1+4+8=13)

Note that addresses must be set with no power applied to the system.

3.3 Installation of the FN-LCD-S

The FN-LCD-S should be mounted so that it is accessible to service personnel and located in an area in compliance with local regulations.

The FN-LCD-S may be surface or flush mounted. Do not mount directly to a concrete wall. Use a suitable standoff material such as plywood to keep condensation away from the annunciator.

The FN-LCD-S must be located within 4,000 feet of the FireNET control panel. A suitable communications cable for RS485 applications must be used for the RS485 bus circuit.

The FN-LCD-S operates in the same manner as the main panel operator interface and controls. For operations and programming, refer to the FireNET Installation and Operation manual that was provided with the panel equipment.

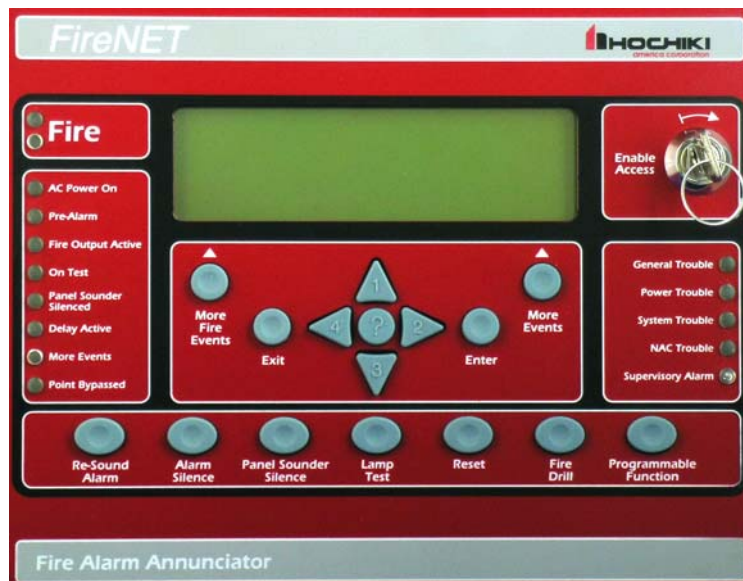

FN-LCD-S Serial LCD Annunciator

3.4 Power Connections

The FN-LCD-S annunciator requires 24 VDC power to operate. The AUX 24V terminals of the FireNET control panel may supply this voltage (500 milliamps maximum), or you may use an external power supply that provides 24 VDC output.

Connections are provided on the annunciator for both incoming and outgoing power.

The FN-LCD-S current draw is as follows:

- Standby: 20mA @ 24VDC
- Alarm: 110mA @ 24VDC

When powering the FN-LCD-S from the FireNET Plus auxiliary 24VDC power (limited to 500mA) or an external UL864/1481 Listed AUX 24VDC supply, the following maximum wiring distances apply to the power cables at the gauges noted:

| Wire Run | Wire AWG | | | | |
|----------|----------|----|----|----|----|
| | 20 | 18 | 16 | 14 | 12 |
| 1000 ft. | 6 | 9 | 15 | 15 | 15 |
| 2000 ft. | 3 | 4 | 7 | 12 | 15 |
| 3000 ft. | 2 | 3 | 5 | 8 | 13 |
| 4000 ft. | 1 | 2 | 3 | 6 | 10 |

3.4.1 Using the Power Output of the FN-LCD-S

NOTE: When connecting FN-4127-I/O Input/Output boards to the FN-LCD-S via the COMMS terminals shown above, the I/O boards must be powered by a UL864/1481 listed local Auxiliary 24VDC power supply, or the Aux 24VDC output of the FN-LCD-S within the limits outlined below.

DO NOT connect the I/O board power input to the Aux 24VDC output terminals of the FN-LCD-S unless the sum current load of the I/O board is within the 500mA max 24VDC output rating of the FN-LCD-S and within the 500mA max 24VDC output rating of the FireNET control panel that provides power to the FN-LCD-S. Failure to make this consideration may result in overloading the FN-LCD-S and/or the control panel Aux 24VDC output (500mA max. each).

The current limits during both standby and in alarm shall not exceed the 500mA rating of the FireNET Aux 24VDC output or FN-LCD-S.

3.5 COMMS Connection

In addition to power, each annunciator requires a pair of conductors for data communication. This wiring is connected to the COMMS + and - terminals on the FireNET control panel. If more than one serial annunciator or another RS485 bus device is being used, it may be connected to the COMMS OUT + and - terminals of the previous RS485 bus device.

3.6 Terminating

The last device connected to the RS485 bus must have a terminating jumper installed at position J3. Even if only 1 annunciator is connected to the panel this jumper must be installed.

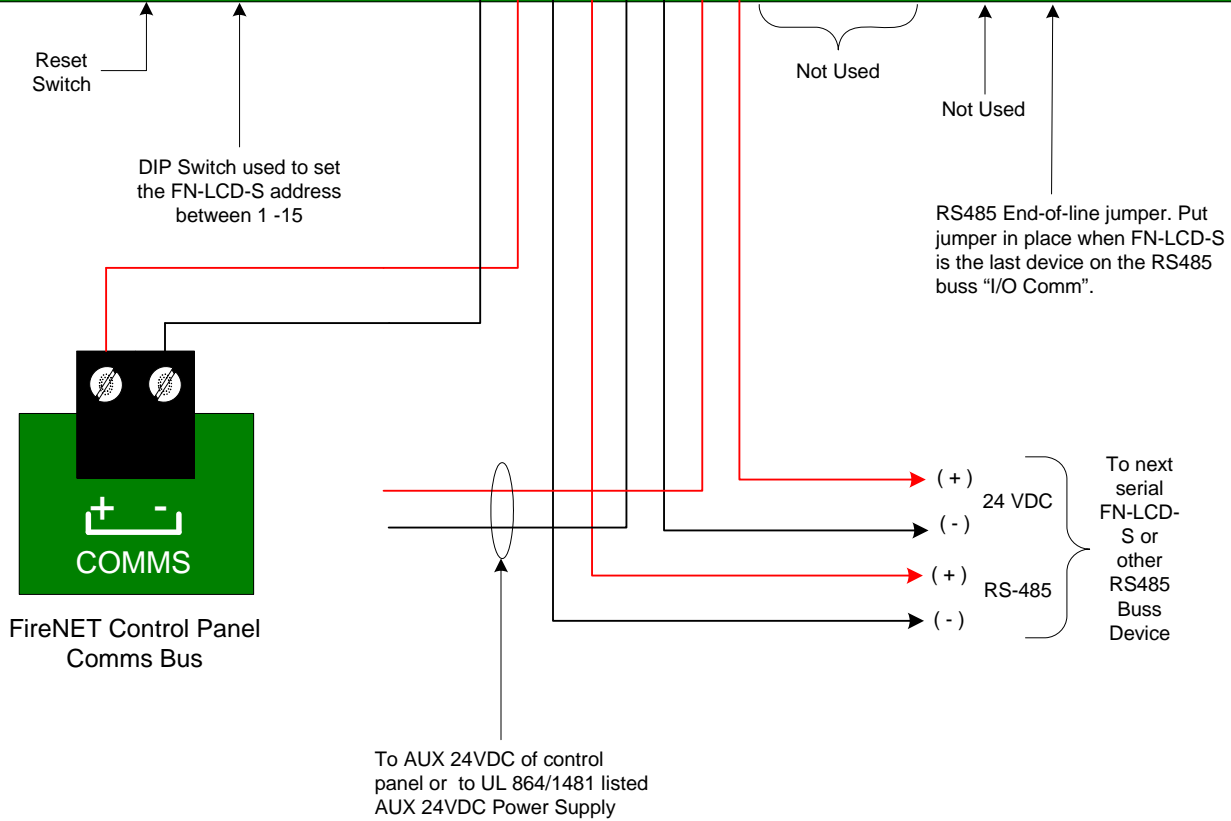
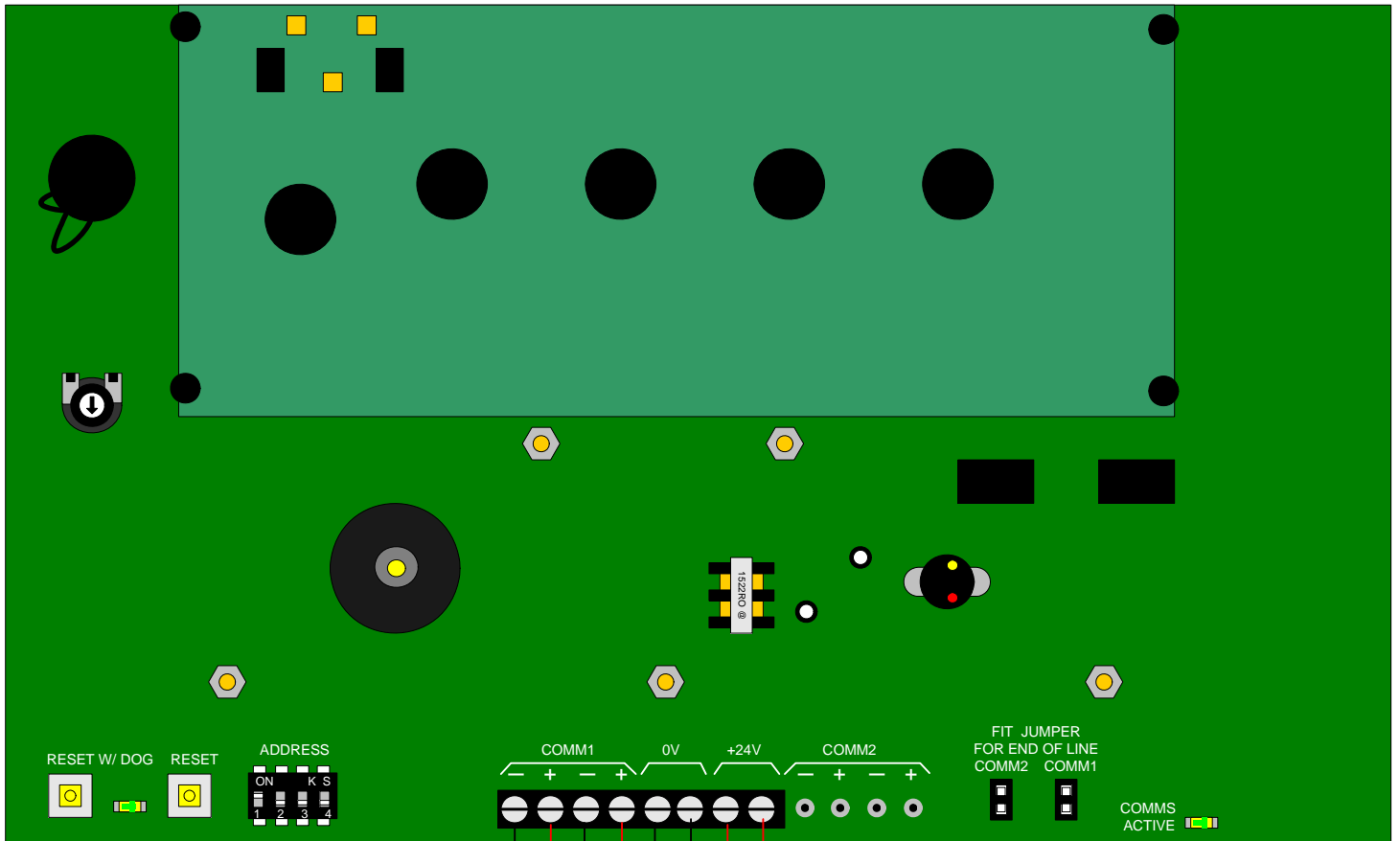

FN-LCD-S Wiring Detail

3.7 Programming the FireNET Panel for the Annunciator

The FireNET panel must be configured to operate with the FN-LCD-S serial annunciator. This can be accomplished by performing an auto-learn on the FireNET panel, or the serial annunciator may be added to the configuration using the Loop Explorer programming tool

Note that performing an auto-learn will erase all programming in the control panel and return all settings to default!

For more information on programming the FireNET control panel, please see the FireNET Installation and Operation manual (P/N 1700-09948).

Section 4 – Operation of the FN-LCD-S Serial Annunciator

This section summarizes the basic operation of the FN-LCD-S annunciator when handling Fire, Trouble, Supervisory and Pre-Alarm conditions. For additional details please see the FireNET Installation and Operation manual.

4.1 Fire Condition

In the event a device on the FireNET fire alarm system activates in a fire alarm condition the following will happen:

- The FIRE LED indicator on the annunciator will turn on and flash.
- Details of the device that caused the fire alarm condition will be given in the LCD status display on the annunciator.
- If there are more than two fire conditions, press the “**More Fire Events**” button on the annunciator to view the additional fire alarms.
- Audible and visual notification appliances (horn and strobes) will activate throughout the building.
- Output relays and circuits will operate performing fire alarm functions such as closing doors, recalling elevators, shutting down air handling equipment etc.
- The buzzer in the annunciator will be pulsing.

The operator actions required following a fire alarm condition are as follows:

- Silence the buzzer by entering access level 2 and pressing the “**Panel Sounder Silence**” button.
- Silence the notification appliances by entering Access Level 2 and pressing the “**Alarm Silence**” button. When the Fire condition is silenced, the fire LED indicator will change from flashing to steady and the LCD display will indicate “Alarm Silenced”.
- Resound the audible and visual notification appliances if necessary by entering Access Level 2 and pressing the “**Resound Alarm**” button.
- Once the fire department has cleared the building, physically reset any devices such as manual pull stations that require a manual reset.
- Reset the FireNET fire alarm control panel by entering Access Level 2 and pressing the “Reset” button on the panel or annunciator.

4.2 Trouble Condition

Trouble conditions occur when problems with the FireNET fire alarm system components and wiring are detected.

When the fire alarm control panel senses a trouble condition, the following will occur.

- The General Trouble LED will illuminate on the annunciator.
- Other LED's indicating the nature of the trouble may also illuminate.
- Details of the trouble condition will be shown on the LCD status display on the annunciator.
- If there is more than one trouble event press the “**More Events**” button to view them in the LCD status display on the annunciator.
- The buzzer in the annunciator will sound.

The operations required following a trouble condition are as follows:

- Silence the buzzer by entering access level 2 and pressing the “**Panel Sounder Silence**” button.
- Note the LCD status display and any messages that may appear so these can be relayed to service personnel.
- Investigate the cause of the trouble. It may be as simple as a detector that was inadvertently removed.
- If the trouble condition cannot be resolved, contact your service company.

There is no need to reset trouble conditions. They are non-latching and reset themselves after the trouble condition is corrected.

NOTE: Loop Open/Short troubles are latching and require a panel reset to clear.

4.3 Supervisory Condition

A supervisory condition is detected when a portion of a building system that controls the spread of fire or smoke is disabled. This is most commonly a fire sprinkler valve that is turned off for maintenance purposes.

When the FireNET fire alarm control panel senses a supervisory condition the following will occur:

- The Supervisory LED will illuminate on the annunciator.
- Details of the supervisory condition will be shown on the LCD status display on the annunciator.
- The buzzer in the annunciator will sound.

The operations required following a supervisory condition are as follows:

- Silence the buzzer by entering access level 2 and pressing the **“Panel Sounder Silence”** button.
- Note the LCD status display and any messages that may appear so these can be relayed to service personnel, fire department, and/or central station.
- Investigate the cause of the supervisory conditions.
- If the supervisory condition cannot be resolved, contact your service company.
- Once the supervisory condition has been cleared, reset the FireNET fire alarm control panel by entering Access Level 2 and pressing the “Reset” button.

4.4 Pre-Alarm Condition

A Pre-Alarm condition occurs when an analog sensor reaches its pre-alarm threshold, or when an input whose type is set to pre-alarm activates. This condition typically occurs as the sensor approaches its fire point.

When the FireNET fire alarm control panel senses a pre-alarm condition, the following will occur:

- The Pre-Alarm LED will illuminate on the annunciator.
- Details of the pre-alarm condition will be shown on the LCD status display on the annunciator.
- If there are multiple events, press the “More Events” button to view them in the LCD status display on the annunciator.
- The buzzer in the annunciator will sound.

The operations required following a Pre-Alarm condition are as follows:

- Silence the buzzer by entering access level 2 and pressing the “**Panel Sounder Silence**” button.
- Note the LCD status display and any messages that may appear so these can be relayed to service personnel.
- Investigate the cause of the Pre-Alarm, such as a significant presence of smoke, heat, or an actual fire starting.
- If the Pre-Alarm condition cannot be resolved, contact your service company.
- Once the Pre-Alarm condition has been cleared, reset the FireNET fire alarm control panel by entering access level 2 and pressing the “reset” button.

WARRANTY

Hochiki America Corporation manufactured equipment is guaranteed to be free from defects in materials and workmanship for a period of one (1) year from date of original shipment. HOCHIKI will repair or replace, at its option, any equipment which it determines to contain defective material or workmanship. Said equipment must be shipped to HOCHIKI prepaid. Return equipment will be prepaid by HOCHIKI. We shall not be responsible to repair or replace equipment which has been repaired by others, abused, improperly installed, altered or otherwise misused or damaged or exposed to conditions outside the products specifications in any way. Unless previously contracted by HOCHIKI, HOCHIKI will assume no responsibility for determining the defective or operative status at the point of installation, and will accept no liability beyond the repair or replacement of the product at our factory service department. Please contact HOCHIKI's Sales department for proper procedure for claims and return of merchandise.

**Hochiki America Corporation
7051 Village Drive, Suite 100
Buena Park, CA 90621-2268
1-800-845-6692
technicalsupport@hochiki.com**

End of Manual

February 2009