



FireSwitch108

10A NAC Power Extender

Installation Guide

SIGNALING



Table of Contents:

Overview	pg. 3
Specifications	pg. 3
Power Supply Specifications	
Power Supply Specifications	pg. 3
Stand-by Specifications	pg. 3
Installation Instructions	pg. 3
Terminal Identification Table	
Logic Board	pg. 6
Power Supply Board	pg. 7
LED Diagnostics	pg. 7
Wiring Diagram	pg. 8
Connection Diagram	pg. 9
Programming	pg. 9
Testing and Maintenance	pg. 11
FireSwitch User Interface and Programming via Ethernet Port	pg. 12
Battery Calculation Worksheet	pg. 13
FireSwitch Applications	
General Information	pg. 14
Class A and Class B Connections	pg. 14
Combination CO and Fire Alarm Connections	pg. 15
Non-Synchronizable NAC Appliances	pg. 15
Using Multiple NAC Power Extenders from an FACP	pg. 16
Synchronizing NAC Power Extender Using Built-In Sync Protocol	pg. 16
Synchronizing multiple NAC Power Extender units	pg. 17
Using a Single FACP Output	pg. 19
Appendix A - UL/cUL Listed Devices Compatible for Synchronization	pg. 20
Appendix B - UL Listed Compatible Devices	pg. 23
Enclosure Dimensions	pg. 24

Overview:

Altronic **FireSwitch108** is a cost effective managed NAC Power Extender. It interfaces with 12 or 24VDC Fire Alarm Control Panels (FACP) to provide Notification Appliance Circuit expansion support, for additional horns/strobes to allow ADA compliancy. It also provides auxiliary power to support system accessories. It delivers electronically regulated and filtered 24VDC power to Class B or Class A NAC loop circuits. Additionally, a separate 1A auxiliary output for 4-wire smoke detectors is available. Alarm current can be divided between the eight (8) outputs for powering NAC devices. Outputs are rated at 2.5A max., and can be independently programmed for Steady, Temporal Code 3 or Strobe Synchronization. All outputs may be programmed for Input to Output Follower Mode (output will follow input. i.e. March Time Input, March Time Output). In non-alarm condition independent loop supervision for Class A and/or Class B FACP NAC circuits is provided. In the event of a loop trouble, the FACP will be notified via the steered input (Input 1 or Input 2). In addition, there are common trouble output terminals [NC, C, NO] which are used to indicate general loop/system trouble. Two (2) FACP signaling outputs can be employed and directed to control supervision and power delivery to any combination of the eight (8) outputs. It provides a programmable LCD display interface, plus an ethernet port interface for remote programmability and monitoring.

Specifications:

Agency Listings:

- **UL 864** Control Units and Accessories for Fire Systems
- **UL 2017** General Purpose Signaling Devices and Systems.
- **CAN/ULC-S527-99** Control units for Fire Alarm Systems.
- **Factory Mutual** Approved.
- **CSFM** Approved.
- **NFPA 72** and **NFPA 720** Compliant.

Input:

- Power input: 120VAC, 60Hz, 4.8A.
- Two (2) Class A or two (2) Class B FACP inputs.
- Two (2) configurable inputs trigger via Class A or Class B FACP signal circuits (polarity reversal) or dry contacts.

Output:

- 24VDC voltage regulated power-limited NAC outputs.
- **Output power:**
 - 10A max. total alarm current.
 - 7A max. stand-by without battery backup.
 - 1A with battery backup including dedicated Aux. output.

For Canadian applications Standby with battery backup is limited to 0.45A.

- 2.5A max current per output.
- One (1) auxiliary output rated at 1A (regulated, battery backed up).
0.45A for Canadian applications.
- Any NAC can be configured as an Aux. output with or without battery back-up (special application only). When set as Aux. output, the output is not supervised. Use UL Listed end of line device for the applications if supervision is required.
- Programmable supervised indicating circuit outputs: Eight (8) Class B or Four (4) Class A, or any combination of Class A and Class B circuits.
- Thermal and short circuit protection with auto reset.

Battery Backup:

- Built-in charger for sealed lead acid or gel type batteries.
- Automatic switchover to stand-by battery when AC fails.
- Zero voltage drop when switching over to battery backup.

Supervision:

- AC fail supervision (form "C" contact, 1A/28VDC).
- Battery presence and low battery supervision (form "C" contact, 1A/28VDC).
- AC local dry contact output (form "C" contact, 1A/28VDC).

Visual Indicators:

- LCD display - Indicates troubles and conditions of operation. Trouble Condition Memory facilitates quick identification of an intermittent/fault (short circuit, open or ground) which has previously occurred on one or more signaling circuit outputs. LCD displays which output the fault has occurred on.

Special Features:

- Programmable LCD display interface.
- EOL resistor value is programmable by output.
- Ethernet port interface for remote programmability and monitoring. All programming needs to be confirmed and tested on site, to assure that the FireSwitch is operating as intended after completion of programming (*refer to FireSwitch User Interface and Programming via Ethernet Port, pgs. 9-11*).
- 2-wire horn/strobe Sync mode allows audible notification appliances (horns) to be silenced while visual notification appliances (strobes) continue to operate.
- Sync protocols include CooperWheclock[®], Gentex[®], Potter and System Sensor[®].
- Temporal Code 3, Steady Mode, Input to Output Follower Mode (maintains synchronization of notification appliances circuit).
- Compatible with 12VDC or 24VDC fire panels.
- Output loop supervision directed to Input 1 or Input 2.
- Common trouble Dry NC output for reporting trouble to remote FACP.
- Ground fault detection - Ground fault maximum test impedance 1,000 Ohm.
- Ground fault Dry NO output to report ground fault to remote FACP.
- CO Temporal Code 4 (NFPA720) include Gentex[®], Potter and System Sensor[®] devices.

Enclosure Dimensions (H x W x D):

15.5" x 12" x 4.5" (393.7mm x 304.8mm x 114.3mm)

Power Supply Specifications:

AC Input	120VAC, 60Hz, 4.8A.
Output	Eight (8) regulated supervised NAC output circuits, 24VDC, 2.5A maximum current. 10A max. total alarm current (configurable as Special Application Aux. outputs). 7A max. stand-by without battery backup. 1A max with battery backup including Aux. output. One (1) regulated aux. output rated at 24VDC @ 1A with battery backup (see stand-by specifications below). <i>0.45A for Canadian applications.</i> Total output current in alarm condition must not exceed 10A.
Battery	Use two (2) 12VDC/12AH or two (2) 12VDC/7AH or two (2) 12VDC/40AH batteries connected in series.
Stand-by/Alarm Current Consumption	180mA/200mA
EOL Resistor (end of line)	Default 10K (10,000 Ohm), Altronix Model # AL-EOL10. <i>(EOL10K-C for Canadian applications)</i>
Ground fault maximum test impedance	1,000 Ohm.
Maximum Loop impedance	1 Ohm.

Stand-by Specifications:

Stand-by Batteries	Stand-by/Alarm	Aux. Current/Battery Back-up
24VDC/7AH	24 Hrs./5 mins.	No auxiliary current (battery backed up)
24VDC/12AH	24 Hrs./5 mins.	50mA auxiliary max. current (battery backed up)
24VDC/40AH	24 Hrs./5 mins.	1A auxiliary max. current (battery backed up)
24VDC/40AH	24 Hrs./30 mins.	0.45A auxiliary max. current (battery backed up) <i>for Canadian Applications</i>

Note: Unit is equipped with one (1) 1A max. auxiliary output (*0.45A for Canadian applications*): “AUX” NAC outputs programmed for “AUX” with battery backup will remain battery backed up during power outage. For loads connected to “AUX” please, refer to battery “Stand-by Specifications” above for ratings. When loads are connected to the “AUX” output during alarm condition, and total current from AUX and remaining outputs may not exceed total alarm current for the particular FireSwitch model. Aux outputs are not supervised.

To provide supervision use a UL Listed end of line relay or similar method.

Installation Instructions:

Wiring methods shall be in accordance with the National Electrical Code NFPA 70/NFPA 72/ANSI/Canadian Electrical Code/CAN/ULC-S524/ULC-S527/ULC-S537 and with all local codes and authorities having jurisdiction. Product is intended for indoor dry use only.

Carefully review:

<i>Power Supply Specifications</i>	(pg. 3)
<i>Stand-by Specifications</i>	(pg. 3)
<i>Terminal Identification</i>	(pgs. 6-7)
<i>LED Diagnostics</i>	(pg. 7)
<i>Programming</i>	(pgs. 9-11)
<i>Testing and Maintenance</i>	(pg. 11)

- Mount the unit in desired location. Mark and predrill holes in the wall to line up with the top two keyholes in the enclosure.

Install two upper fasteners and screws in the wall with the screw heads protruding. Place the enclosure’s upper keyholes over the two upper screws; level and secure. Mark the position of the lower two holes. Remove the enclosure. Drill the lower holes and install the two fasteners.

Place the enclosure’s upper keyholes over the two upper screws. Install the two lower screws and make sure to tighten all screws (*Enclosure Dimensions, pg. 24*). Secure enclosure to earth ground (*Fig. 1, pg. 4*). Small terminal block wire gauges range from 16 AWG to 22 AWG, all others range from 12 to 22 AWG.

- Connect the line [L] and neutral [N] terminals to a separate unswitched 20A protected branch circuit (120VAC, 60Hz) dedicated to the Fire Alarm System. Connect ground to the ground lug (*Fig. 1, pg. 4*). Use 12 AWG wire.

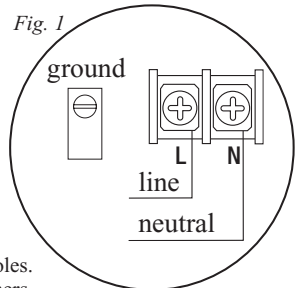
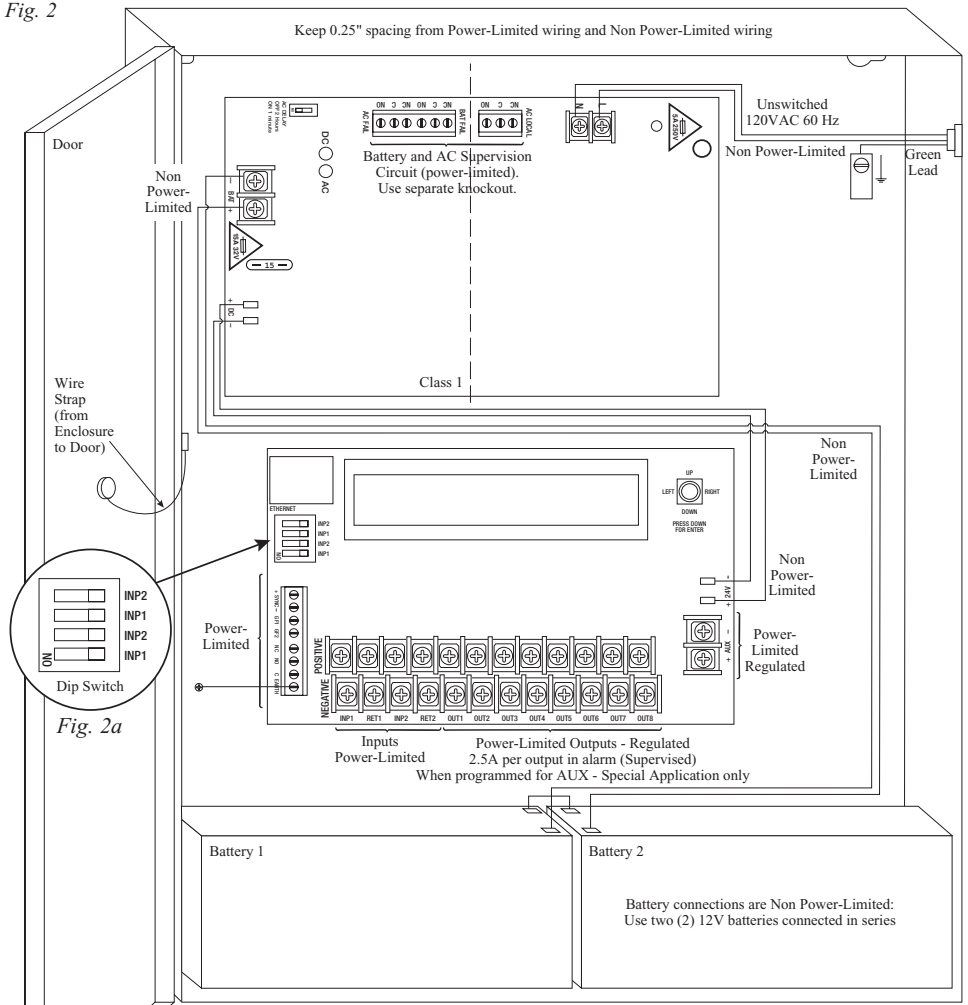

Fig. 2



3. Connect two (2) 12VDC batteries wired in series to terminals marked [- BAT +] (Fig. 2, pg. 5).
Note: If batteries being used in your installation do not fit into the FireSwitch unit, it is required to install a separate enclosure UL Listed for appropriate application. Separate battery enclosure is required to have 50 cubic inches of additional open space. All wiring methods shall be in accordance with the National Electrical Code NFPA 70/NFPA 72/ANSI/Canadian Electrical Code/CAN/ULC-S524/ULC-S527/ULC-S537 and with all local codes and authorities having jurisdiction. Battery circuits are not Power-Limited provide 0.25" spacing from Power-Limited circuits use separate knockout. If additional battery enclosure is required it must be UL Listed for the application and mounted within 5' of the FireSwitch enclosure in the same room, minimum 12 AWG wire in appropriate conduit is required for connection. When using conduit, make sure it is installed in a matter where it can not turn.
4. To trigger NAC outputs via the FACP signaling circuit(s) (polarity reversed) set INP1 and INP2 DIP switches to the OFF position. To trigger NAC outputs via the FACP dry relay contact (normally closed NC) set INP1 and INP2 DIP switches to the ON position (Fig. 2a, pg. 5).
5. Determine the functionality of outputs [OUT1 through OUT8]. Outputs can be programmed as Class "A" NACs, Class "B" NACs, Aux. power output(s) with battery backup or Aux. power output(s) without battery backup.
Note: Not all devices can use the sync feature.
 Be sure to check Appendix A to ensure the device you have chosen will work with this feature.
Note: When programming outputs for Aux. power it will not be affected by the FACP trigger input. (Refer to Fig. 4, pg. 8 for Wiring, for Programming refer to pg. 9).

6. Determine which NAC input will trigger the desired NAC output(s).
7. Select output options (*for Programming refer to pgs. 9-11*).
Note: The 2-wire horn/strobe sync mode will only synchronize horns, horn/strobes, strobes with synchronization capability. For Class B outputs connect EOL (AL-EOL10) to the last device in each NAC Loop. For applications in Canada use EOL10K-C end of line resistors (to be ordered separately). Form the leads to fit the terminals. Bend radius can not exceed 0.125". Do not bend closer than 0.25" to the body of the resistor.
8. Connect desired 24VDC devices to regulated Aux. power output terminals marked [+ AUX –] (*Fig. 2, pg. 5*). Output is Power-Limited. 0.25" spacing from Non Power-Limited wiring must be provided. Use separate knockout.
9. Connect Digital Communicator or Local Annunciator to Common Trouble Output terminals marked [NC, NO, C] (*Fig. 2, pg. 5*).
10. Connect appropriate signaling notification devices to terminals marked [AC FAIL & BAT FAIL] supervisory relay outputs (*Fig. 2, pg. 5*).
11. Program **FireSwitch** utilizing on-board programming switch or via ethernet port (*for Programming refer to pgs. 9-11*). When using ethernet port, cable has to terminate within the same building.

Amount of Notification Appliances that can be Synchronized:

Altronix Model	Max. Per Circuit	Max. Per FireSwitch108
FireSwitch108	32	128

Terminal Identification Table:

Logic Board

Terminal Legend	Function/Description
+ 24V IN –	24VDC input from power supply.
+ AUX –	This separate 1A max. auxiliary regulated output circuit is typically used to power 4-wire smoke detectors - <i>0.45A for Canadian applications</i> . See attached list of devices (<i>Appendix B, pg. 23</i>).
OUT1 - OUT8 (Supervised)	Notification appliances are connected to these regulated outputs. Each power limited output will supply up to 2.5A. Outputs are controlled by designated Input 1 [IN1] or Input 2 [IN2] (<i>Output Configuration Chart, pg. 9</i>). Maximum line impedance 1 Ohm. NAC outputs that are programmed as AUX are Special Application.
IN1 +, IN1 – IN2 +, IN2 – (Supervised)	These terminals connect to the 24VDC FACP notification appliance circuit outputs. Class A or Class B Input trigger voltage is 8-33VDC @ 6.5mA min. Terminal polarity is shown in alarm condition. During an alarm condition these inputs will cause the selected outputs chosen to drive notification appliances. The designated outputs are programmable [OUT1 through OUT8] (<i>Output Configuration Chart, pg. 9</i>). A trouble condition on an output loop will cause the corresponding input to trip the FACP by opening the FACP loop. An alarm condition will always override trouble to drive notification appliances.
RET1 +, RET1 – RET2 +, RET2 – (Supervised)	For Class A connections these terminal pairs return to FACP. For Class B connections use FACP EOL resistor to terminate at these terminals. Optionally, additional signaling circuit power supplies may be connected to these terminals. If this option is chosen, the EOL resistor must be terminated at the last device. Up to twelve (12) units can be interconnected.
EARTH	Connects to the grounding lug of the enclosure (factory installed).
C, NO, NC (Common trouble output)	These are dry contact trouble outputs that report any general loop/system trouble conditions. In addition, Factory set to report AC and Battery trouble. Feature can be optionally turned off. See Programming section, <i>pg. 9-11</i> . (Typically used to trigger a digital communicator or other reporting devices). (form "C" contact 1A / 28VDC, 0.35 Power Factor) (<i>Fig. 2, pg. 5</i>).
+ SYNC –	Designed to be connected to [+ INP1 –] or [+ INP2 –] of Altronix FireSwitch models only. Maximum of four (4) units can be interconnected, the distance between the units should not exceed 20 ft., wiring to be in conduit, 20 AWG wire minimum. FireSwitch108 NAC power extenders must be located in the same room.
GF1 GF2	Dry normally open contact. It will close if ground fault is detected. Use to report ground fault condition to a host FACP. Can be wired between [+] or [–] coming from FACP and earth ground.

Terminal Identification Table:

Power Supply Board

Terminal Legend	Function/Description
L, G, N	Connect 120VAC to these terminals: L to Hot, N to Neutral. Earth Ground should be connected via grounding lug.
+ DC -	24VDC non power- limited output.
AC FAIL (delayed) NO, C, NC	Form "C" dry contacts indicate the loss of AC, with AC present terminals marked [NO] and [C] are open, [NC] and [C] are closed. When loss of AC occurs terminals marked [NO] and [C] are closed, [NC] and [C] are open.
AC LOCAL (instant) NO, C, NC	Form "C" dry contacts used to instantaneously signal the loss AC to local annunciation devices, with AC present terminals marked [NO and C] are open, [NC and C] are closed. When loss of AC occurs terminals marked [NO and C] are closed, [NC and C] are open.
BAT FAIL NO, C, NC	Form "C" dry contacts indicate low battery voltage or loss of battery voltage. Under normal conditions terminals marked [NO and C] are open, [NC and C] are closed. During a trouble condition terminals marked [NO and C] are closed, and [NC and C] are open (Fig. 2, pg. 5).
- BAT +	Stand-by battery input (leads provided). Maximum charging voltage is 26.4VDC, maximum charging current is 1.5A (Fig. 2, pg. 5).

*Power Supply Board Parameter Specifications:

NOTICE TO USERS, INSTALLERS, AUTHORITIES HAVING JURISDICTION, AND OTHER INVOLVED PARTIES			
This product is field-configurable. In order for the product to comply with the requirements in the Standard for Control Units and Accessories for Fire Alarm System (UL 864), set programming features as indicated below.			
Program feature or option	Permitted in UL 864? (Y/N)	Possible Settings	Settings Permitted in UL 864
AC Reporting Delay	Yes	2 hours or 1 minute	1 hour to 3 hours
AC Trouble Reporting to host panel	Yes	enable/disable	enable
BAT Trouble Reporting to host panel	Yes	enable/disable	enable

- To set AC Delay for 2 hours or 1 minute - power the unit down (AC supply and Battery) prior to changing switch position - Turn switch "AC Delay" ON or OFF, respectively (Fig. 3, pg. 7).
- Factory setting is 2 hours - for testing purposes change to 1 minute by turning AC Delay switch ON temporarily.
- Low battery condition will report at approximately 20VDC.
- Battery presence detection will report within 100 seconds after battery remains undetected (missing or removed).
A restored battery will report within 30 seconds.

Fig. 3

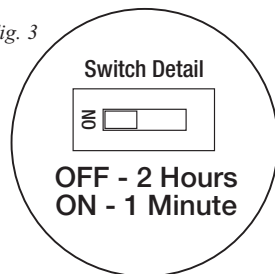

LED Diagnostics:

Power Supply Board

Red (DC)	Green (AC)	Power Supply Status
ON	ON	Normal operating condition.
ON	OFF	Loss of AC. Stand-by batteries supplying power.
OFF	ON	No DC output.
OFF	OFF	Loss of AC. Discharged or no stand-by battery. No DC output.

Wiring Diagram:

Fig. 4

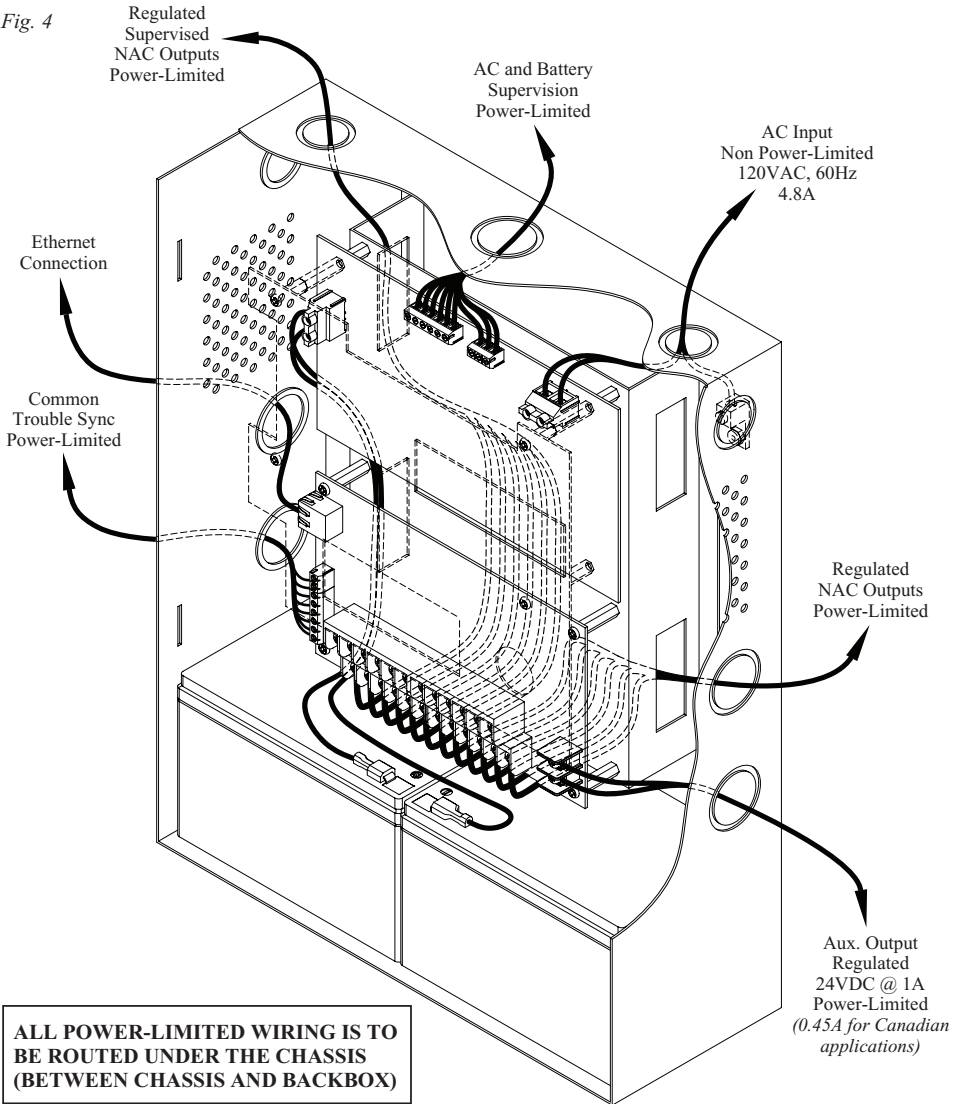

Connection Diagram:

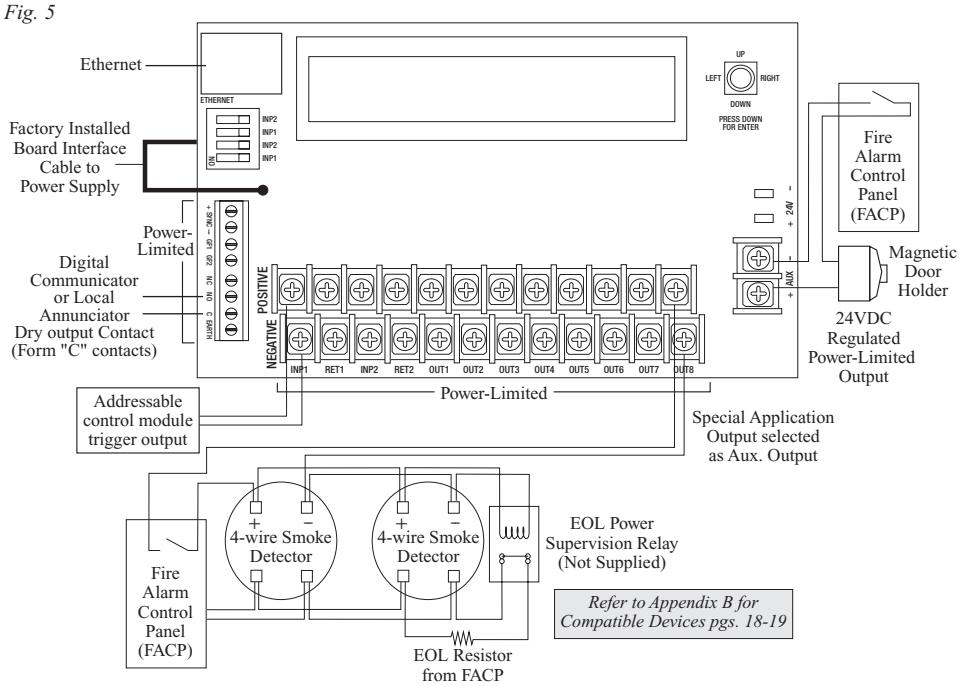

Programming:

To begin programming depress and hold down the joystick (approximately 2 secs.).

Note: If *FireSwitch* remains dormant for more than 90 seconds, it will return to stand-by status screen.

Step 1. Setup Outputs 1-8:

- a. Select from: Class A, Class B or Aux. Outputs with or without battery backup (see chart below).

Output Configuration:

LCD Legend	Function/Description
A	Class A output (Combines two (2) outputs, ex. 1-2, 3-4, 5-6, 7-8).
B	Class B output.
Ax	Aux. output with battery backup.
Bx	Aux. output without battery backup.

- b. Depress the joystick one time from Stand-by screen.
- c. Use [Up/Down] to select Function, Use [Left/Right] to select channel.

Step 2. Program Protocol for Channels 1-8:

- a. Select from: Steady, Code 3, Follower Mode, Potter, Carbon Monoxide (CO) Strobes, Carbon Monoxide (CO) Horns, Gentex[®], System Sensor[®] or CooperWheelock[®].

Protocol Selection:

LCD Legend	Function	Triggered From	Description
1a	Steady	Input 1	A steady output signal will be generated. This mode will accept steady or pulsing input.
2a		Input 2	
3a		Redundant - Input 1 and Input 2.	
1b	Code 3	Input 1	Enables Temporal Code 3 signal generation output. This mode will accept a steady or a pulsing input.
2b		Input 2	
3b		Redundant - Input 1 and Input 2.	
1c	Follower Mode	Input 1	Output follows signal it receives from the corresponding input (i.e. FACP Sync module - maximum synchronization of notification appliance circuit).
2c		Input 2	
3c		First Input to go in alarm mode.	
1d	Amseco/Potter	Input 1 (both horns and strobes).	This mode is designed to work with the Amseco/Potter series of horns, strobes, and horn/strobes to provide a means of synchronizing the Temporal-coded horns, synchronizing the one-second flash timing of the strobe, and silencing the horns of the horn/strobe combination over a two-wire circuit while leaving strobes active.
2d		Input 2 (both horns and strobes).	
3d		Input 1 - strobes only. Input 2 - horns and strobes.	
1e	Carbon Monoxide (CO)	Input 1 and Input 2 - strobes only.	This mode is designed to generate strobe sync signal during both fire alarm and CO alarm. See Combination CO and Fire Alarm Connections on Pg. 15.
2e		Input 1 and Input 2 - horns only.	This mode is designed to generate Code 3 horn temporal code during fire alarm and Temporal 4 for system CO alarms during CO alarm. See Combination CO and Fire Alarm Connections on Pg. 15.
3e		Reserved	Reserved
1f	Gentex [®] Gentex is a registered trademark of Gentex Corporation.	Input 1 (both horns and strobes).	This mode is designed to work with the Gentex [®] series of horns, strobes, and horn/strobes to provide a means of synchronizing the Temporal-coded horns, synchronizing the flash timing of the strobe, and silencing the horns of the horn/strobe combination over a two-wire circuit while leaving strobes active.
2f		Input 2 (both horns and strobes).	
3f		Input 1 - strobes only. Input 2 - horns and strobes.	
1g	System Sensor [®] System Sensor is a registered trademark of Honeywell.	Input 1 (both horns and strobes).	This mode is designed to work with the System Sensor [®] series of horns, strobes, and horn/strobes to provide a means of synchronizing the Temporal-coded horns, synchronizing the flash timing of the strobe, and silencing the horns of the horn/strobe combination over a two-wire circuit while leaving strobes active.
2g		Input 2 (both horns and strobes).	
3g		Input 1 - strobes only. Input 2 - horns and strobes.	
1h	CooperWheelock [®] CooperWheelock is a registered trademark of CooperWheelock.	Input 1 (both horns and strobes).	This mode is designed to work with the CooperWheelock series of horns, strobes, and horn/strobes to provide a means of synchronizing the Temporal-coded horns, synchronizing the one-second flash timing of the strobe, and silencing the horns of the horn/strobe combination over a two-wire circuit while leaving strobes active.
2h		Input 2 (both horns and strobes).	
3h		Input 1 - strobes only, Input 2 - horns and strobes.	

- b. Depress the joystick one (1) time from Function screen or two (2) times from Stand-by screen.
c. Use [Up/Down] to select Protocol, Use [Left/Right] to select outputs.
d. Use [Right] to copy setting to next output.

Note: Class A outputs are paired. If output is set for Ax or Bx - Protocol settings are not available.

Step 3. EOL Resistor Value Programming

- Depress the joystick three (3) times from Stand-by screen, or two (2) times from Function Screen, or one (1) time from Protocol screen.
- Use [Up/Down] to select the appropriate value (*see chart below*).
- Use [Left/Right] to select the output.

Programmed Digit	0	1	2	3	4	5	6	7
Resistor Value	2.2K	2.8K	3.9K	4.7K	5.1K	10K	22K	43K

Step 4. Read/Clear Trouble Memory

- Depress the joystick three (3) times from Stand-by screen, or two (2) times from Function Screen, or one (1) time from Protocol screen.

Trouble Memory LCD Indication:

LCD Legend	Trouble Condition
A	AC trouble.
B	Battery trouble.
C	Common trouble.
N	Normal operating condition.
O	Loop open or open circuit.
S	Loop Shorted.
G	Loop Ground fault.
?	Loop wiring is incorrect.

- Use [Down] to reset all stored troubles.

Step 5. AC and Battery Trouble Reporting and Sounder Alert Options

- Depress the joystick four (4) times from Stand-by screen, or three (3) times from Function Screen, or two (2) times from Protocol screen, or one (1) time from Trouble Memory screen.
- Use [Up/Down] to select/de-select reporting option.
- Use [Left/Right] to select AC/BAT/ALERT or to enable/disable AC and BAT trouble and ALERT sounder.
- Use [Up/Down] to select the appropriate End of Line Resistor value (2.2K, 2.8K, 3.9K, 4.7K, 5.1K, 10K, 22K, 43K).
- Depress the joystick to exit. **Note:** AC and BAT trouble and ALERT sounder are factory enabled.

Testing and Maintenance:

Unit should be tested at least once a year for the proper operation as follows:

- Output Voltage Test:** Under normal load conditions, the DC output voltage should be checked for proper voltage level.
- Battery Test:** Under normal load conditions check that the battery is fully charged, check specified voltage both at battery terminal and at the board terminals marked [- BAT +] to ensure that there is no break in the battery connection wires.
- Note:** Expected battery life is 5 years; however it is recommended changing batteries in 4 years or less if needed.

Test operation of unit as follows:

- Ground fault test:** Directly short one leg of the circuit to chassis ground. The ground fault and trouble fault should be indicated.
- NAC open circuit test:** Remove the EOL resistor from the last device on the circuit. Open trouble should be indicated.
- NAC short circuit test:** Place a short across each NAC output individually. NAC short should be indicated.
- Disconnect Battery:** BAT trouble should be indicated.
- Reset Trouble Memory.**

FireSwitch User Interface and Programming via Ethernet Port:

Note: Service person must be present on site to confirm changes by holding “down” position of joystick.

Step 1.

Set Local Area Connection of your laptop to DHCP mode.

For Windows XP:

- a. Open Network Connections by clicking **Start** button, then clicking Settings, then clicking Network Connections.
- b. Right click the **Local Area Connection**. Click **Properties**. Administrator permission required If you are prompted for an administrator password or confirmation, type the password or provide confirmation.
- c. Double click **Internet Protocol (TCP/IP)** menu item.
- d. Choose the **Obtain an IP address automatically** option.
- e. Click **OK**. Close all windows.

For Windows Vista:

- a. Open Network Connections by clicking the **Start** button Picture of the Start button, clicking **Control Panel**, clicking **Network and Internet**, clicking **Network and Sharing Center**, and then clicking **Manage Network Connections**.
- b. Right click the **Local Area Connection**. Click **Properties**. Administrator permission required If you are prompted for an administrator password or confirmation, type the password or provide confirmation.
- c. Click the **Networking** tab. Under this connection uses the following items, click either **Internet Protocol Version 4 (TCP/IPv4)** or **Internet Protocol Version 6 (TCP/IPv6)**, and then click **Properties**.
- d. To specify IPv4 IP address settings, click **Obtain an IP address automatically**, and then click **OK**.
- e. To specify IPv6 IP address settings, click **Obtain an IPv6 address automatically**, and then click **OK**.

For Windows 7:

- a. Open Network Connections by clicking the **Start** button Picture of the Start button, clicking **Control Panel**, clicking **Network and Internet**, clicking **Network and Sharing Center**, and then clicking **Change Adapter Settings**.
- b. Right click the **Local Area Connection**. Click **Properties**. Administrator permission required. If you are prompted for an administrator password or confirmation, type the password or provide confirmation.
- c. Click the **Networking** tab. Under this connection uses the following items, click either **Internet Protocol Version 4 (TCP/IPv4)** or **Internet Protocol Version 6 (TCP/IPv6)**, and then click **Properties**.
- d. To specify IPv4 IP address settings, click **Obtain an IP address automatically**, and then click **OK**.
- e. To specify IPv6 IP address settings, click **Obtain an IPv6 address automatically**, and then click **OK**.

Step 2.

Connect a laptop or PC to the Ethernet port of your *FireSwitch* unit.

FireSwitch unit should be powered up at this moment.

Step 3.

Open a browser window (it is necessary to update your browser software to the latest version so that the pages display and function correctly).

Step 4.

Enter the IP address (the default IP address is 192.168.168.168) into the address bar.

Status page will be displayed.

Step 5.

Click Setup link. You will be prompted for an administrative password, type and submit the password (the default password is “11111111”). Setup page will be displayed. You may now program your *FireSwitch*.

Battery Calculation Worksheet

Device	Number of Devices	Current per Device	Stand-by Current	Alarm Current	
For each device use this formula:		This column x This column = Equals	Current per number of devices.		
FireSwitch108 (Current draw from battery)	1	Stand-by:	180mA	180mA	
		Alarm:	200mA		200mA
A	FireSwitch Current			180mA	200mA
Auxiliary Devices		Refer to device manual for current ratings.			
		Alarm/Stand-by	mA	mA	mA
		Alarm/Stand-by	mA	mA	mA
		Alarm/Stand-by	mA	mA	mA
B	Auxiliary Devices Current (must not exceed 1A; 0.45A for Canadian applications)				
		Refer to device manual for current ratings.			
		Alarm:	mA	0mA	mA
		Alarm:	mA	0mA	mA
		Alarm:	mA	0mA	mA
		Alarm:	mA	0mA	mA
C	Notification Appliances Current must not exceed 10A (10,000mA)		0mA		mA
D	Total alarm current (A + B + C)			mA	mA
E	Total current ratings converted to amperes (line D x .001)			A	A
F	Number of standby hours (24 for NFPA 72, Chapter 1, 1-5.2.5).			H	
G	Multiply lines E and F.	Total stand-by	AH	AH	
H	Alarm sounding period in hours. (For example, 5 minutes = 0.0833 hours.)				H
I	Multiply lines E and H.	Total alarm	AH		AH
J	Add lines G and I.	Total stand-by and alarm	AH	AH	
K	Multiply line J by 1.30. (30% extra insurance to meet desired performance) Total ampere - hours required			AH	

If total ampere - hour required exceeds 40AH, decrease AUX current to provide enough stand-by time for the application. Select a battery with AH rating equal to or greater than the value calculated.

FireSwitch Applications:

1. General Information:

Altronix **FireSwitch** units are very versatile devices. They can be used with or without specific synchronization modules provided by some manufacturers. Multiple units can be synchronized by using either the built-in sync mode or a external synchronization module. Please note that only notification appliances with synchronization capabilities can be synchronized. Contact signal manufacturer for more detailed information. Units can operate with either one (1) or two (2) outputs from the FACP.

2. Class A and Class B Connections:

Units can be used with the outputs configured for:

- Four (4) Class A (Fig. 6).
- Up to eight (8) Class B.
- Combination of Class A and Class B outputs (Fig. 7).

Fig. 6

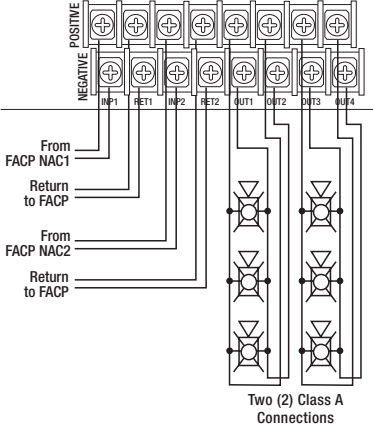

NAC Loop	Starts On	Terminates On
1	OUT 1	OUT 2
2	OUT 3	OUT 4
3	OUT 5	OUT 6
4	OUT 7	OUT 8

Please make sure corresponding outputs are programmed appropriately.

Fig. 7

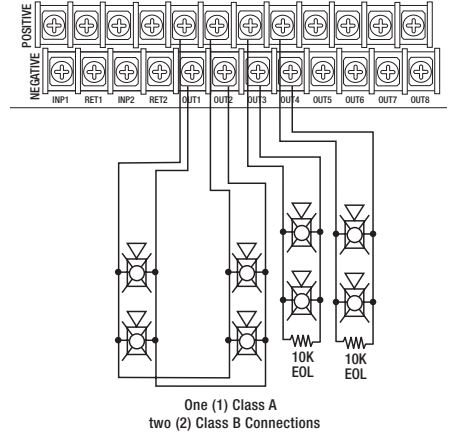

Combination of two (2) Class B and one (1) Class A circuit.

3. Combination CO and Fire Alarm Connections:

To comply with requirements of applicable UL and NFPA standards Fire Systems (UL 864), General Purpose Signaling Devices and Systems (UL 2017), CAN/ULC-S527-99 Control units for Fire Alarm Systems, NFPA 72, and NFPA 720 audible and visual notification appliances have to be used on different circuits. Systems has to be monitored by a supervising station and emergency response provided in accordance with NFPA 720.

CO combination mode settings are not accessible through IP interface. In CO alarm mode the unit will indicate CO alarm which will be superseded by fire alarm, if fire alarm is initiated. In order for CO alarm mode to operate, horns and strobes have to be wired separately. The outputs for strobes should be programmed for 1e mode. The outputs for horns should be programmed for 2e mode. FACP has to initiate output 2 only during CO alarm and Output 1 and Output 2 during fire alarm condition.

To silence the horns during fire alarm condition Output 2 has to be turned off, but Output 1 has to stay on. During CO alarm (Input 2 initiated only) horns will generate CO alert sequence (Temporal 4 pattern) and strobes will flash every second. During fire alarm condition (Input 1 only or Inputs 1 and 2) strobes will flash and horns will generate Temporal3 pattern, unless silenced.

Programming and LCD Legend:

LCD Legend	Description
1e	Generates strobe sync signal
2e	Generates T3 horn temporal pattern or T4 temporal pattern (see above).

Horn settings for CO alarm:

Gentex, Potter - Horns must be set to Steady mode.
System Sensor - Horns must be set for a coded output.

4. Non-Synchronizable NAC Appliances:

When using NAC appliances not designed to support synchronization feature, it is recommended to use separate output circuits for audible notification appliances (horns) and visual notification appliances (strobes).

Program the FireSwitch to follow Input 1 [IN1] and for audible notification appliances to follow Input 2 [IN2]. This will allow, when using two (2) outputs from the FACP, to support silencing of audible notification appliances. When using only one (1) FACP output, program to follow Input 1 [IN1]. The units outputs can each be set for the desired NAC drive signal, such as Code 3 (Output Programming Selection Table, pg. 9). Non-synchronizable Audible Appliances will follow the sequence, when feature is selected.

Fig. 8

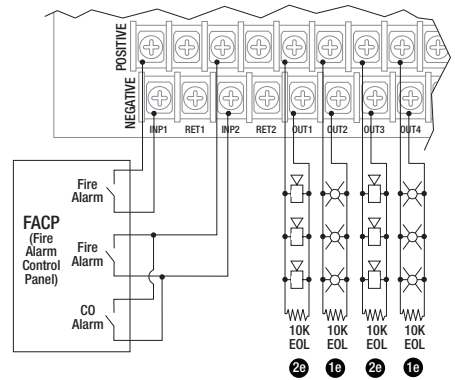
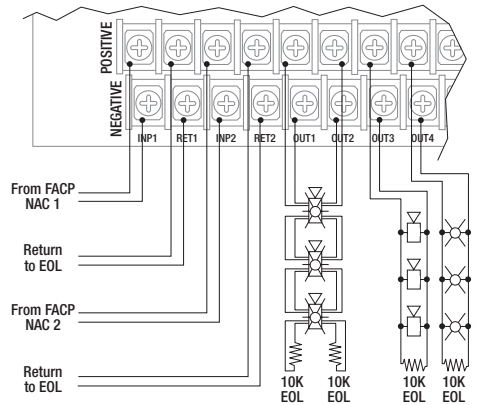

Fig. 9



5. Using Multiple NAC Power Extenders from an FACP:

FireSwitch is designed to follow (replicate) the coded sequence, generated by a manufacturer's sync module. Up to eleven (11) *FireSwitch108* units can be synchronized when interconnected with a host FACP. Connect the output of the FACP module to Input 1 and Input 2. Terminate the input circuit with the EOL (FACP), connecting it to terminals marked [RET +] and [RET -] to [INP +] and [INP -] of the next unit when multiple units need to be triggered.

In case FACP does not have any synchronization capabilities and the sync mode is not used, the notification appliance synchronization will not be provided.

Fig. 10

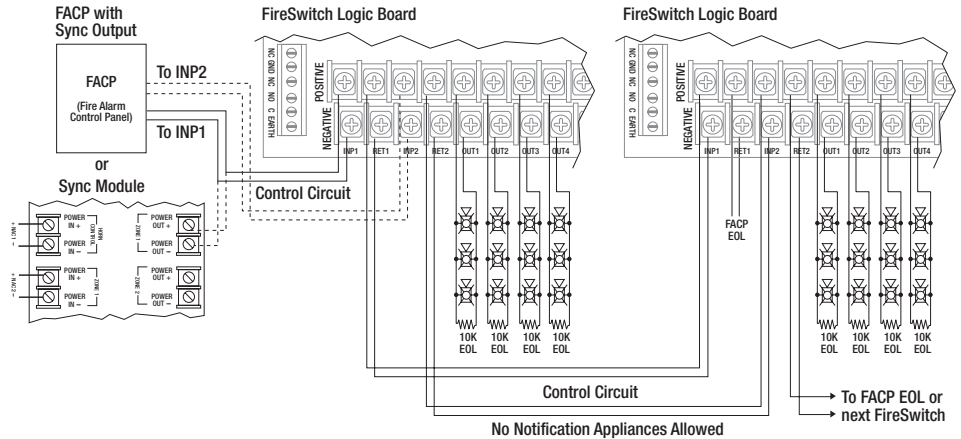

Caution: Do not connect any notification appliances on the control circuit interconnecting FACP outputs (sync module outputs) and inputs of NAC Power Extenders. Applications that do not employ synchronization module or FACP with synchronization protocol will not provide NAC synchronization between NAC Power Extenders.

Altronic Model	Max. Per Circuit	Max. Per FireSwitch108
FireSwitch108	32	128

6. Synchronizing NAC Power Extender Using Built-In Sync Protocol:

FireSwitch units include built-in protocols to support Amseco/Potter, Gentex®, System Sensor®, or CooperWheellock® two-wire synchronizable devices, therefore an external sync module is not required (*Output Programming Selection Table, pg. 9*). In these modes, Input 1 is always used to activate visual notification appliances (strobes), and Input 2 is used to activate and silence audible notification appliances (strobes) (*Table, pg. 9*). **Note:** Input 1 has to be activated in all the configurations.

7. Synchronizing multiple NAC Power Extender units (up to twelve):

Method 1 allows up to twelve (12) units to be synchronized (Fig. 10, pg. 16).

Method 2 allows up to four (4) units to be synchronized (Fig. 11, pg. 17).

Fig. 11

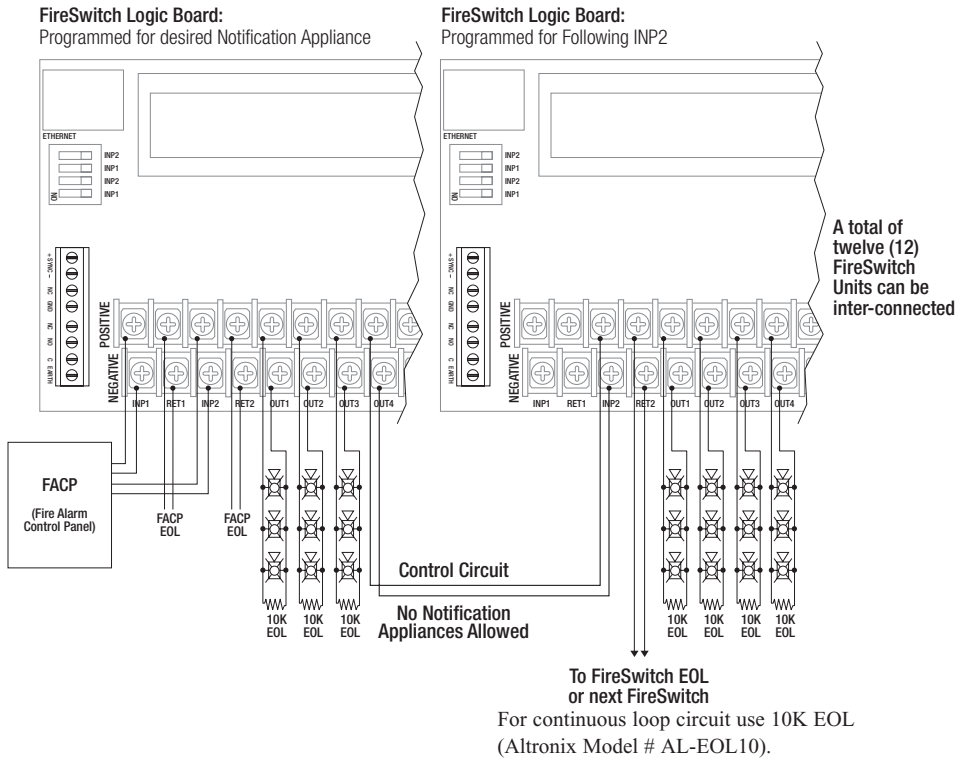

When connecting, keep wires on different sides of the screw terminals in order to maintain loop integrity supervision. DO NOT LOOP CONTINUOUS WIRE AROUND THE SCREW.

Altronix Model	Max. Per Circuit	Max. Per FireSwitch108
FireSwitch108	32	128

Fig. 12

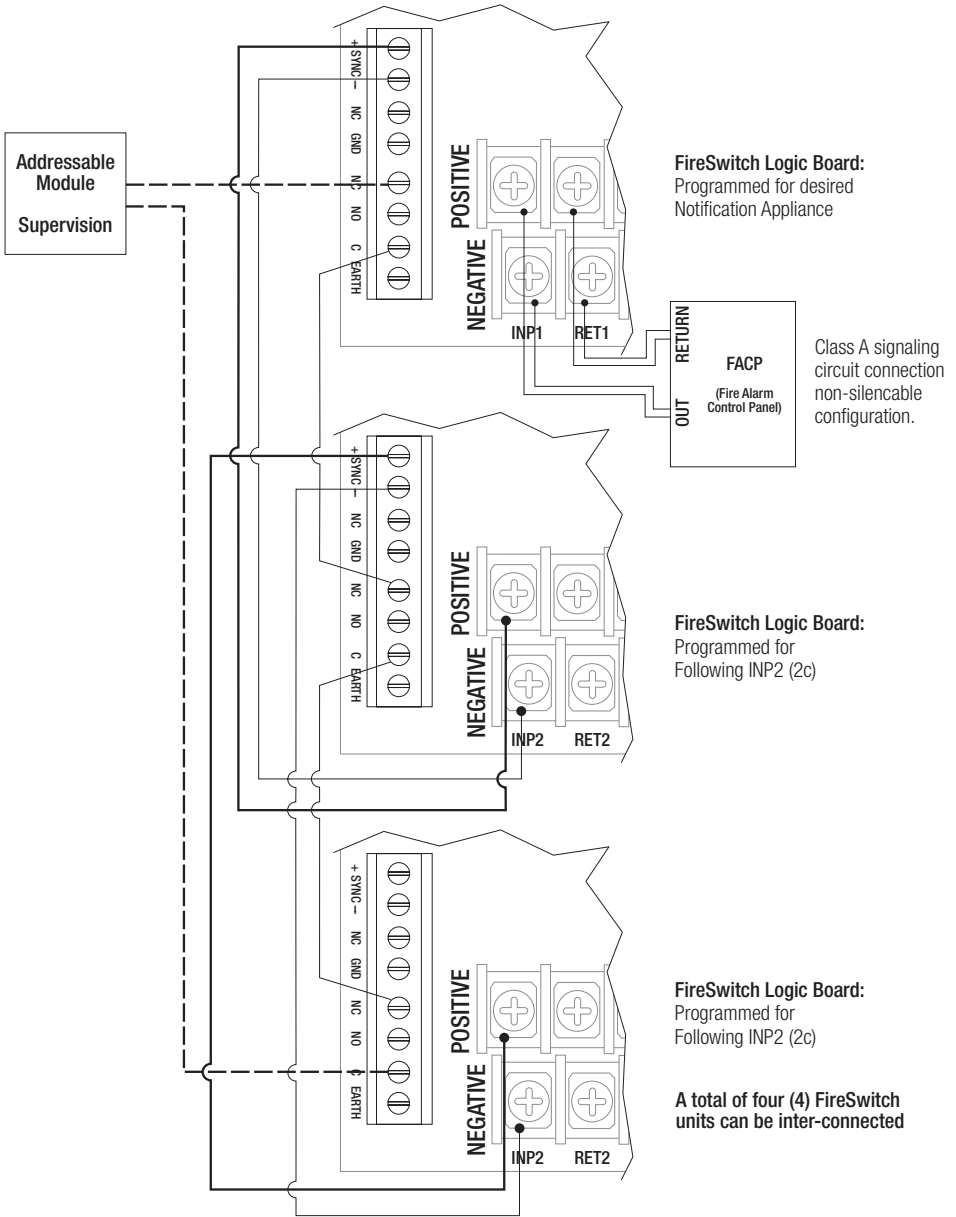

For this application set Dip Switches for INP2 to "ON" position on all units, except the one triggered from FACP

8. Using a Single FACP Output:

When only one FACP output is available, you may connect both Input1 and Input2 to it. Wire [RET1+] and [RET1-] to [INP2+] and [INP2-]. Both visual and audible notification appliances will be activated simultaneously (Fig. 13, pg. 19).

Fig. 13

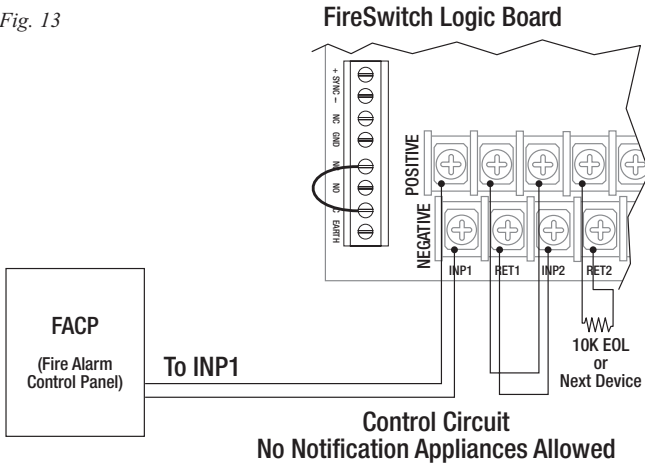

Dip Switches 1-4 Settings:

Dry contact INP1 configuration set SW1 and SW3 to the ON position.
Dry contact INP2 configuration set SW2 and SW4 to the ON position.

When connecting INP1 to the sync output of *FireSwitch* unit for synchronization purposes set SW1 to the ON position and SW3 to the OFF position. For INP2 to the sync output of *FireSwitch* unit for synchronization purposes set SW2 to the ON position and SW4 to the OFF position.

	SW1	SW2	SW3	SW4
INP1 - Dry NC	ON	–	ON	–
INP2 - Dry NC	–	ON	–	ON
INP1 - Sync	ON	–	OFF	–
INP2 - Sync	–	ON	–	OFF

Appendix A - UL/cUL Listed Devices Compatible for Synchronization

A-1 Strobes, Horns, and Horn/Strobes

Table A-1 below lists Strobes, Horns, and Horn/Strobes compatible with *FireSwitch* NAC outputs.

Gentex:

GCS24CR - UL	GCCB24PCR / W - UL	GEC24-15/75WR - UL
GCS24CW - UL	GCCG24PCR / W - UL	GEC24-15/75WW - UL
GCS24PCR - UL	GCCR24PCR / W - UL	SSPK24CLPR - UL
GCS24PCW - UL	WGESA24-75PWR / W - UL	SSPK24CLPW - UL
GCC24CR - UL	WGESB24-75PWR / W - UL	SSPK24WLP - UL
GCC24PCR - UL	WGESG24-75PWR / W - UL	SSPK24WLPW - UL
GCC24CW - UL	WGESR24-75PWR / G - UL	SSPK24AWR - UL
GCC24PCW - UL	WGECA24-75PWR / W - UL	SSPK24AWW - UL
GEC3-24WR - UL	WGECB24-75PWR / W - UL	SSPK24-15/75WLP - UL
GEC3-24WR - UL	WGECG24-75PWR / W - UL	SSPK24-15/75WLPW - UL
GEH24-R - UL	WGECR24-75PWR / G - UL	SSPK24-15/75AWR - UL
GEH24-W - UL	WGESA24-75PWLPR / W - UL	SSPK24-15/75AWW - UL
WGES24-75WR / WW - UL	WGESB24-75PWLPR / W - UL	SSPKA24-15/75PWR - UL
WGES24-75PWR / PWW - UL	WGESG24-75PWLPR / W - UL	SSPKA24-15/75PWW - UL
WGES24-75WRLP / WWLP - UL	WGESR24-75PWLPR / W - UL	SSPKA24-15/75AWR - UL
WGEC24-75WR / WW - UL	WGECA24-75PWLPR / W - UL	SSPKA24-15/75AWW - UL
WGEC24-75PWR / PWW - UL	WGECB24-75PWLPR / W - UL	SSPKB24-15/75PWR - UL
WGEC24-75WRLP / WWLP - UL	WGECG24-75PWLPR / W - UL	SSPKB24-15/75PWW - UL
WGEC24-75PWLPR / WWLP - UL	WGECR24-75PWLPR / W - UL	SSPKG24-15/75PWR - UL
GESA24PWR / W - UL	GX91-R / W - UL/cUL	SSPKG24-15/75PWW - UL
GESB24PWR / W - UL	GX91-PR / W - UL/cUL	SSPKR24-15/75PWR - UL
GESG24PWR / W - UL	GX93-R / W - UL/cUL	SSPKR24-15/75PWW - UL
GESR24PWR / W - UL	GX93-PR / W - UL/cUL	WSSPKA24-15/75AWR - UL
GECA24PWR / W - UL	WSSPK24-15/75WR / WW - UL	WSSPKA24-15/75AWW - UL
GECB24PWR / W - UL	WSSPK24-15/75PWR / PWW - UL	WSSPKA24-15/75PWR - UL
GECG24PWR / W - UL	WSSPK24-15/75AWR / AWW - UL	WSSPKA24-15/75PWW - UL
GECR24PWR / W - UL	GES24-177WR - UL	WSSPKB24-15/75PWR - UL
GCSA24PCR / W - UL	GES24-177WW - UL	WSSPKB24-15/75PWW - UL
GCSB24PCR / W - UL	GES24-15/75WR - UL	WSSPKG24-15/75PWR - UL
GCSG24PCR / W - UL	GES24-15/75WW - UL	WSSPKG24-15/75PWW - UL
GCSR24PCR / W - UL	GEC24-177WR - UL	WSSPKR24-15/75PWR - UL
GCCA24PCR / W - UL	GEC24-177WW - UL	WSSPKR24-15/75PWW - UL

System Sensor:

CHSR - UL	P4R-SP - UL	PC4RH-P - UL	SPSCW - UL	SPSWK-CLR-ALERT - UL
CHSW - UL	P4RH - UL	PC4RH-SP - UL	SPSCW-CLR-ALERT - UL	SPSWK-P - UL
HR/HRK/HW - UL	P4RH-P - UL	PC4W - UL	SPSCW-P - UL	SPSWK-R - UL
MHR - UL	P4RH-SP - UL	PC4W-P - UL	SPSCWH - UL	SPSWV - UL
MHW - UL	P4RK - UL	PC4W-SP - UL	SPSCWH-P - UL	SPSWV-P - UL
P1224MC - UL	P4RK-R - UL	PC4WH - UL	SPSCWHK - UL	SR - UL
P2R - UL	P4W - UL	PC4WH-P - UL	SPSCWHK-P - UL	SR-P - UL
P2R-P - UL	P4W-P - UL	PC4WH-SP - UL	SPSCWK - UL	SR-SP - UL
P2R-SP - UL	P4W-SP - UL	PC4WHK - UL	SPSCWK-CLR-ALERT - UL	SRH - UL
P2RH - UL	P4WH - UL	PC4WK - UL	SPSCWK-R - UL	SRH-P - UL
P2RH-LF - UL	P4WH-P - UL	SCR - UL	SPSCWV - UL	SRH-SP - UL
P2RH-P - UL	P4WH-SP - UL	SCR-P - UL	SPSCWV-P - UL	SRHK - UL
P2RH-SP - UL	P4WK - UL	SCR-SP - UL	SPSCWVH - UL	SRHK-P - UL
P2RHK - UL	PC2R - UL	SCRH - UL	SPSCWVH-P - UL	SRHK-R - UL
P2RHK-P - UL	PC2R-P - UL	SCRH-P - UL	SPSR - UL	SRK - UL
P2RHK-R - UL	PC2RH - UL	SCRH-SP - UL	SPSR-P - UL	SRK-P - UL
P2RK - UL	PC2RH-P - UL	SCRHK - UL	SPSRH - UL	SRK-R - UL
P2RK-P - UL	PC2RH-SP - UL	SCRK - UL	SPSRH-P - UL	SW - UL
P2RK-R - UL	PC2RHK - UL	SCW - UL	SPSRHK - UL	SW-ALERT - UL
P2W - UL	PC2RK - UL	SCW-CLR-ALERT - UL	SPSRK - UL	SW-CLR-ALERT - UL
P2W-P - UL	PC2W - UL	SCW-P - UL	SPSRK-P - UL	SW-P - UL
P2W-SP - UL	PC2W-P - UL	SCW-SP - UL	SPSRK-R - UL	SW-SP - UL
P2WH - UL	PC2W-SP - UL	SCWH - UL	SPSRV - UL	SWH - UL
P2WH-LF - UL	PC2WH - UL	SCWH-P - UL	SPSRV-P - UL	SWH-ALERT - UL
P2WH-P - UL	PC2WH-P - UL	SCWH-SP - UL	SPSW - UL	SWH-P - UL
P2WH-SP - UL	PC2WH-SP - UL	SCWHK - UL	SPSW-ALERT - UL	SWH-SP - UL
P2WHK - UL	PC2WHK - UL	SCWK - UL	SPSW-CLR-ALERT - UL	SWHK - UL
P2WHK-P - UL	PC2WK - UL	SPSCR - UL	SPSW-P - UL	SWHK-P - UL
P2WK - UL	PC4R - UL	SPSCRH - UL	SPSWH - UL	SWK - UL
P2WK-P - UL	PC4R-P - UL	SPSCRV - UL	SPSWH-P - UL	SWK-P - UL
P4R - UL	PC4R-SP - UL	SPSCRVH - UL	SPSWK - UL	
P4R-P - UL	PC4RH - UL			

Potter/Amseco:

CM24CR - UL	CSL-1224W-BW - UL/cUL	MH-12/24W - UL/cUL	SSC8-177R - UL
CM24CW - UL	CSL-1224W-GR - UL/cUL	SCM24C-177R - UL	SSC8-177W - UL
CSH-1224W-AR - UL/cUL	CSL-1224W-GW - UL/cUL	SCM24C-177W - UL	SSC8-3075110R - UL
CSH-1224W-AW - UL/cUL	CSL-1224W-RR - UL/cUL	SCM24C-3075110R - UL	SSC8-3075110W - UL
CSH-1224W-BR - UL/cUL	CSL-1224W-RW - UL/cUL	SCM24C-3075110W - UL	SSR2-177R - UL
CSH-1224W-BW - UL/cUL	CSL24CAW - UL/cUL	SH-1224R - UL/cUL	SSR2-177W - UL
CSH-1224W-GR - UL/cUL	CSL24C-BW - UL/cUL	SH-1224W - UL/cUL	SSR2-3075110R - UL
CSH-1224W-GW - UL/cUL	CSL24C-GW - UL/cUL	SH-1224WP-R - UL/cUL	SSR2-3075110W - UL
CSH-1224W-RR - UL/cUL	CSL24C-RW - UL/cUL	SH-1224WP-W - UL/cUL	SSR8-177R - UL
CSH-1224W-RW - UL/cUL	CSL24C-AR - UL/cUL	SH24C-177R - UL/cUL	SSR8-177W - UL
CSH24C-AW - UL/cUL	CSL24C-BR - UL/cUL	SH24C-177W - UL/cUL	SSR8-3075110R - UL
CSH24C-BW - UL/cUL	CSL24C-GR - UL/cUL	SL-1224R - UL/cUL	SSR8-3075110W - UL
CSH24C-GW - UL/cUL	CSL24C-RR - UL/cUL	SL-1224W - UL/cUL	SSS2-1530R - UL
CSH24C-RW - UL/cUL	H-1224R - UL/cUL	SL-1224WP-R - UL/cUL	SSS2-1530W - UL
CSH24C-AR - UL/cUL	H-1224W - UL/cUL	SL-1224WP-W - UL/cUL	SSS2-75110R - UL
CSH24C-BR - UL/cUL	HP-25TR - UL/cUL	SL-24W - UL/cUL	SSS2-75110W - UL
CSH24C-GR - UL/cUL	HP-25TW - UL/cUL	SSC2-177R - UL	SSS8-1530R - UL
CSH24C-RR - UL/cUL	MH-12/24R - UL/cUL	SSC2-177W - UL	SSS8-1530W - UL
CSL-1224W-AR - UL/cUL	MH-12/24TR - UL/cUL	SSC2-3075110R - UL	SSS8-75110R - UL
CSL-1224W-AW - UL/cUL	MH-12/24TW - UL/cUL	SSC2-3075110W - UL	SSS8-75110W - UL
CSL-1224W-BR - UL/cUL			

Cooper/Wheelock:

50-241575W-FR - UL/cUL	E70-24MCW-FN - UL/cUL	ET90-24MCCH-FN - UL/cUL	LSTW-A* - UL/cUL
AH-24WP-R - UL	E70-24MCW-FR - UL/cUL	ET90-24MCCH-FW - UL/cUL	LSTW-ALA* - UL/cUL
AMT-12/24-R - UL/cUL	E70-24MCW-FW - UL/cUL	HNR - UL/cUL	LSTW-NA* - UL/cUL
AMT-12/24-W - UL/cUL	E70-24MCWH-FN - UL/cUL	HNRC - UL/cUL	LSTW-NA* - UL/cUL
AMT-241575W-FR - UL/cUL	E70-24MCWH-FR - UL/cUL	HNW - UL/cUL	MIZ-24S-R - UL/cUL
AMT-241575W-FR-NYC - UL	E70-24MCWH-FR - UL/cUL	HNWC - UL/cUL	MIZ-24S-W - UL/cUL
AMT-241575W-FW - UL/cUL	E70-24MCWH-FW - UL/cUL	HS-24-R - UL/cUL	MT-12/24-R - UL
AMT-24MCW-FR - UL/cUL	E70H-241575W-FR - UL/cUL	HS-24-W - UL/cUL	MT-241575W-FR - UL/cUL
AMT-24MCW-FW - UL/cUL	E70H-241575W-FW - UL/cUL	HS4-241575W-FR - UL/cUL	MT-241575W-FW - UL/cUL
AS-12100C - UL/cUL	E70H-24MCW-FR - UL/cUL	HS4-24MCC-FR - UL	MT-24MCW-FR - UL/cUL
AS-24100C - UL/cUL	E70H-24MCW-FW - UL/cUL	HS4-24MCC-FW - UL/cUL	MT-24MCW-FW - UL/cUL
ASWP-2475C-FR - UL	E70H-24MCWH-FN - UL/cUL	HS4-24MCW-FR - UL/cUL	MTWP-2475C-FR - UL
ASWP-2475C-FW - UL	E70H-24MCWH-FW - UL/cUL	HS4-24MCW-FW - UL/cUL	MTWP-2475C-FW - UL
ASWP-2475W-FR - UL	E90-24MCC-FN - UL/cUL	HSR - UL/cUL	MTWP-2475W-FR - UL
ASWP-2475W-FW - UL	ET90-24MCC-FW - UL/cUL	HSRC - UL/cUL	MTWP-2475W-FW - UL
ASWP-24MCCH-FR - UL	ET90-24MCC-FN - UL/cUL	HSW - UL/cUL	MTWP-24MCCH-FR - UL
ASWP-24MCCH-FW - UL	E90-24MCC-FR - UL/cUL	HSWC - UL/cUL	MTWP-24MCCH-FW - UL
ASWP-24MCWH-FR - UL	E90-24MCC-FW - UL/cUL	LHNR* - UL/cUL	MTWP-24MCWH-FR - UL
ASWP-24MCWH-FW - UL	E90-24MCCH-FN - UL/cUL	LHNW* - UL/cUL	MTWP-24MCWH-FW - UL
CH70-24MCW-FR - UL/cUL	E90-24MCCH-FR - UL/cUL	LHSR* - UL/cUL	RSS-241575W-FR - UL/cUL
CH70-24MCW-FW - UL/cUL	E90-24MCCH-FW - UL/cUL	LHSR-A* - UL/cUL	RSS-241575W-FW - UL/cUL
CH70-24MCWH-FR - UL/cUL	E90H-24MCC-FR - UL/cUL	LHSR-AL* - UL/cUL	RSS-24MCW-FR - UL/cUL
CH70-24MCWH-FW - UL/cUL	E90H-24MCC-FW - UL/cUL	LHSR-N* - UL/cUL	RSS-24MCW-FW - UL/cUL
CH90-24MCC-FR - UL/cUL	E90H-24MCCH-FR - UL/cUL	LHSW* - UL/cUL	RSS-24MCWH-FR - UL/cUL
CH90-24MCC-FW - UL/cUL	E90H-24MCCH-FW - UL/cUL	LHSW-A* - UL/cUL	RSS-24MCWH-FW - UL/cUL
CH90-24MCCH-FR - UL/cUL	ET90-24MCCH-FR - UL/cUL	LHSW-AL* - UL/cUL	RSSA-24MCC-NW - UL
CH90-24MCCH-FW - UL/cUL	ET-1010-R - UL	LHSW-N* - UL/cUL	RSSA-24MCCH-NW - UL
E50-241575W-FW - UL/cUL	ET-1010-W - UL	LSPSTR* - UL/cUL	RSSB-24MCC-NW - UL
E50-24MCWH-FR - UL/cUL	ET70-241575W-FR - UL/cUL	LSPSTR-AL* - UL/cUL	RSSB-24MCCH-NW - UL
E50-24MCWH-FW - UL/cUL	ET70-241575W-FW - UL/cUL	LSPSTR-ALA* - UL/cUL	RSSG-24MCC-NW - UL
E50H-241575W-FR - UL/cUL	E70-24MCW-FN - UL/cUL	LSPSTR-N* - UL/cUL	RSSG-24MCCH-NW - UL
E50H-241575W-FW - UL/cUL	ET70-24MCW-FR - UL/cUL	LSPSTR-NA* - UL/cUL	RSSR-24MCC-NW - UL
E50H-24MCW-FR - UL/cUL	ET70-24MCW-FW - UL/cUL	LSPSTW* - UL/cUL	RSSR-24MCCH-NW - UL
E50H-24MCW-FW - UL/cUL	ET70-24MCWH-FN - UL/cUL	LSPSTW-AL* - UL/cUL	RSSWP-2475C-FR - UL
E50H-24MCWH-FR - UL/cUL	ET70-24MCWH-FR - UL/cUL	LSPSTW-ALA* - UL/cUL	RSSWP-2475C-FW - UL
E50H-24MCWH-FW - UL/cUL	ET70-24MCWH-FW - UL/cUL	LSPSTW-N* - UL/cUL	RSSWP-2475W-AR - UL
E60-24MCC-FR - UL/cUL	ET70WP-24185W-FR - UL	LSPSTW-NA* - UL/cUL	RSSWP-2475W-FR - UL
E60-24MCC-FW - UL/cUL	ET70WP-24185W-FW - UL	LSTR* - UL/cUL	RSSWP-2475W-FW - UL
E60-24MCCH-FR - UL/cUL	ET70WP-2475C-FR - UL	LSTR-A* - UL/cUL	RSSWP-2475W-NW - UL
E60-24MCCH-FW - UL/cUL	ET70WP-2475C-FW - UL	LSTR-AL* - UL/cUL	RSSWP-24MCCH-FR - UL
E60H-24MCC-FR - UL/cUL	ET80-24MCW-FR - UL/cUL	LSTR-ALA* - UL/cUL	RSSWP-24MCCH-FW - UL
E60H-24MCC-FW - UL/cUL	ET80-24MCW-FW - UL/cUL	LSTR-NA* - UL/cUL	RSSWP-24MCWH-FR - UL
E60H-24MCCH-FR - UL/cUL	ET80-24MCWH-FR - UL/cUL	LSTRW-ALA* - UL/cUL	RSSWP-24MCWH-FW - UL
E60H-24MCCH-FW - UL/cUL	ET80-24MCWH-FW - UL/cUL	LSTW* - UL/cUL	S8-24MCC-FW - UL/cUL
S8-24MCCH-FW - UL/cUL	STH-3R24MCCH-NR - UL	STR-ALB - UL	STW-ALB - UL
SA-S70-24MCW-FR - UL	STH-4M30WC - UL	STR-NA - UL	STW-NA - UL
SA-S70-24MCW-FW - UL	STH-4MS-R - UL	STR-NB - UL	STW-NB - UL
SA-S90-24MCC-FR - UL	STH-4R - UL	STR-NG - UL	STW-NG - UL
SA-S90-24MCC-FW - UL	STH-4R24MCCH-NW - UL	STR-NR - UL	STW-NR - UL
STH-2G - UL	STH-4R24MCCH110B-NR - UL	STRC-NA - UL	STWC-AB - UL
STH-2MS-R - UL	STH-4R24MCCH110R-NA - UL	STRC-NB - UL	STWC-ALA - UL
STH-2R - UL	STH-4R24MCCH110R-NR - UL	STRC-NG - UL	STWC-ALB - UL
STH-2R24MCCH-NR - UL	STH-90-4R24MCCH-NW - UL	STRC-NR - UL	STWC-NA - UL
STH-3MS-R - UL	STR-AB - UL	STW-AB - UL	STWC-NB - UL
STH-3R - UL	STR-ALA - UL	STW-ALA - UL	STWC-NG - UL
			STWC-NR - UL

*When using these model strobes the maximum current per NAC is limited to 2A.

Appendix B - UL Listed Compatible Devices

B.1 Four (4) Wire Smoke Detectors

Table B-1 below lists four (4) wire smoke detectors compatible with *FireSwitch* AUX output and Outputs 1-8 when programmed as AUX.

System Sensor Smoke Detector/Base	Detector Type	Max Stand-by Current (mA)	Alarm Current (mA)
B112LP	Base	0.12	36
B114LP	Base	*	*
B404B	Base	*	*
DH100ACDC	Photoelectric	0.15	0.70
DH100ACDCLP	Photoelectric	0.15	0.70
DH100ACDCLPW	Photoelectric	0.15	0.70
DH400ACDCI	Ionization Duct	25	95
DH400ACDCP	Photoelectric Duct	25	95
1112/24/D	Ionization	0.05	50
1424	Ionization	0.10	41
1451 (w/B402B Base)	Ionization	0.10	39
2112/24ATR	Photoelectric	0.50	60/70
2112/24AITR	Photoelectric	0.50	60/70
2112/24/D	Photoelectric	0.05	50
2112/24R	Photoelectric	0.50	60/70
2112/24TR	Photoelectric	0.50	60/70
2112/24T/D	Photoelectric w/135° Thermal	0.05	50
2112/24TSRB	Photoelectric w/135° Thermal Supervisory Relay	15	45
2312/24TB	Photoelectric	0.12	50
2412 (12 volt)	Photoelectric	0.12	77
2412AT (12 volt)	Photoelectric	0.12	58
2412TH (12 volt)	Photoelectric	0.12	77
2424	Photoelectric	0.10	41
2424TH	Photoelectric	0.10	41
2451	Photoelectric	0.10	39
2451TH (with/B402B Base)	Photoelectric	0.10	39
2W-MOD	Loop Test/Maintenance Mod.	30	50
4W-B (12/24 volt)	Photoelectric I ³	0.05	23
4WT-B (12/24 volt)	Photoelectric I ³ w/Therm	0.05	23
4WTA-B (12/24 volt)	I ³ Photo w/Therm/Sounder	0.05	35
4WTR-B (12/24 volt)	I ³ Photo w/Therm/Relay	0.05	35
4WTR-B (12/24 volt)	I ³ Photo w/Therm/Sounder/Relay	0.05	50
4WITAR-B (12/24 volt)	I ³ Photo w/Isolated Therm/Sounder/Relay	0.05	50
2W-MOD2	I ³ Loop Test/Maintenance Mod.	0.05	*
RRS-MOD	I ³ Reversing Relay/Sync Module	0.05	*
6424	Projected Beam	10	28.4
Beam 1224(S)	Projected Beam	17	38.5

* Contact manufacturer for current draws.

B.2 Relays

Table B-2 below lists relays compatible with *FireSwitch* AUX output and Outputs 1-8 when programmed as AUX.

Manufacturer	Model	Current (mA)	Manufacturer	Model	Current (mA)
System Sensor	PR-1	15	System Sensor	R-20T	40
	PR-2	30		R-24T	40
	PR-3	30		R-10E	23
	EOLR-1	30		R-14E	23
	R-10T	23		R-20E	40
	R-14T	23		R-24E	40

Enclosure Dimensions:

15.5" x 12" x 4.5" (393.7mm x 304.8mm x 114.3mm)

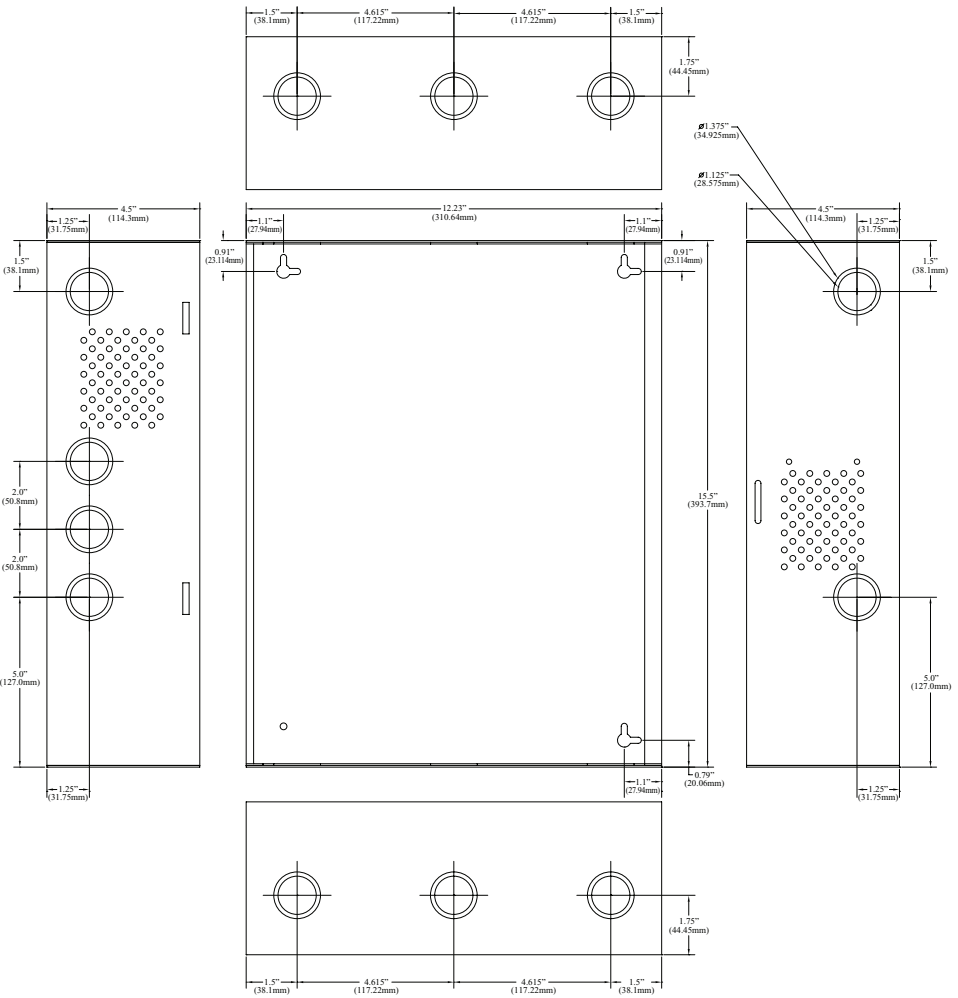

Altronix is not responsible for any typographical errors.

140 58th Street, Brooklyn, New York 11220 USA | phone: 718-567-8181 | fax: 718-567-9056
 website: www.altronix.com | e-mail: info@altronix.com | Lifetime Warranty | Made in U.S.A.

IFireSwitch108

D26R